

By-pass Level Transmitter Operation Manual

TRANSDUCER WIRING DIAGRAM

- 1) User can choose to use either an analogue or digital meter as a terminal display based on the application.
- 2) Please refer to Fig. 1 for the wiring diagram of analogue meter; Fig. 2 for digital meter.
- 3) Digital meter has to come with 24Vdc power supply, 4~20mA Input. Another 24Vdc power supply will be required is there is no 24VDC.
- 4) Digital meter can bring with 2-4 control points setting.
- 5) Please contact us if users need the meters from our company.

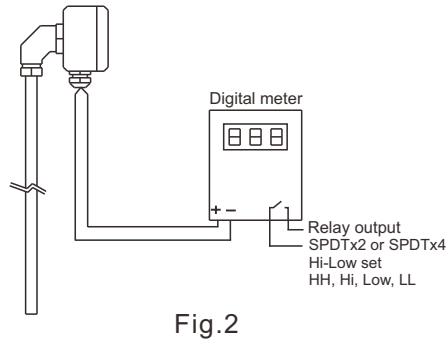
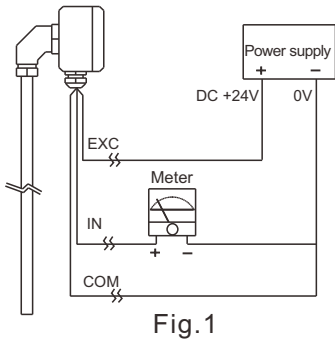

ADJUSTMENT ON TRANSDUCER

1. Position of the flag display, ruler, and the transducer of the level indicator are already setup in our factory based on the order of the customer, so it is suggested that the customer shall not make any adjustment on the abovementioned.
 2. Position of the magnetic switch is adjustable based on customer's application.
 3. When the liquid level doesn't match with the value of the transducer, user can adjust the transducer by following the steps below:
 - a). Put the float in low level position, and adjust "ZERO" to 4-mA.
 - b). Put the float in high level position, and adjust "SPAN" to 20mA.
- ★ **Attention!** To avoid error on measurement, never open the housing to adjust "ZERO" and "SPAN" while the transducer is in operating condition.

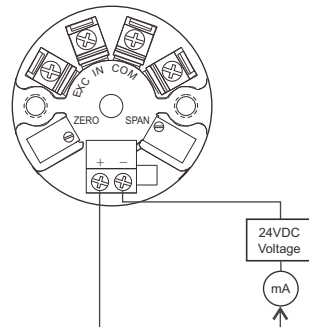

MAGNETIC SWITCH WIRING

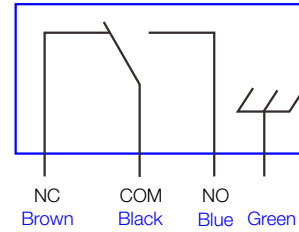

EFB-1220/1230

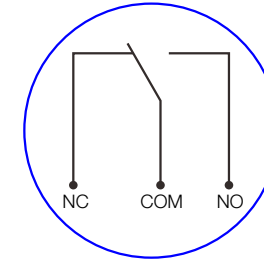

EFB-1250/1260/1300/1310

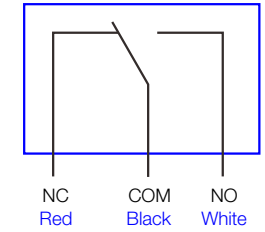

EFB-1420/1430

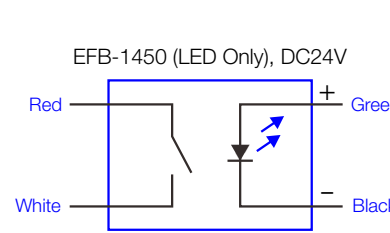

EFB-1400/1410/1440/1450

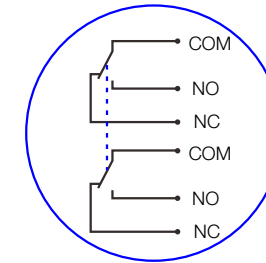

EFB-1800

MAINTENANCE

1. Sediment of detected material might occur at the bottom and wall of the chamber and the float after a period of time of using. It is necessary to clean it off to ensure the accuracy of the display. To clean the chamber, open the bottom flange. Don't reverse the direction of the float while putting the float into the chamber.
2. Conduct regular check on the sealing washer connected to the flange. Ageing washer should be replaced with a new one to prevent leakage.
3. Ensure all fixtures to be tightly secured.
4. Ensure the transducer and the magnetic switch function normally.
5. Turn off the power before opening the transducer and the housing of the magnetic switch.

MAINTAIN

1. Before the installation, please remove the dust cover as indicated in the picture.
2. Level indicator should be vertically mounted on the tank, and the deviation of the vertical degree should be less than 3°.
3. While arranging the connection, always keep the cables away from high temperature articles.
4. Make sure that the Specific Gravity of the detected material is consistent with that shown on the metal plate.
5. Rising speed of the liquid level should be ≤ 1 cm/sec.
6. Make sure no article is in the body of the chamber while installing the level indicator.
7. ON / OFF signals are generated through the interaction of the magnetic switch and the magnetic line, so any magnetic force or magnetic articles should be kept at least 10cm away from the level indicator to avoid interference.
8. When the load of the magnetic switch is an inductive or capacitive, it is necessary to have a RC parallel connection at both ends of the contact to protect the contact.
9. Make sure that all wirings are correctly connected before supplying the power to prevent damage on the magnetic switch.
10. Avoid fierce attack on the magnetic switch to prevent damage on the float.
11. Power supply of the transducer: 24Vdc.
12. While dismounting the level indicator, loosen the bottom flange and take out the float to clean. Make sure to keep the tip of the arrow in the upward direction while putting the float back to the chamber. For customized floats which are without the arrow sign, please keep the heavy end (where the magnet is located) upward while putting it back to the chamber.

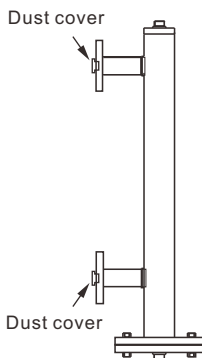

TROUBLE SHOOTING

Abnormal	Possible reason	Remedy
Float inside the level gauge is moving slow or not at all.	Float is stuck by precipitates, impurities.	Clean the chamber and float.
	Float is attracted by magnetic metal part close to the level indicator.	Remove all magnetic metal part, such as metal straps.
	Flange plug is not removed, block the vessel.	Remove the plug on the flange, re-install the unit.
	Float damaged. Float inside with liquid, and float not able to float.	Float has to be replaced.
	Float is not matched specific gravity, causing up and down.	Contact the local sales.
Bi-colored flags misplaced.	Bi-colored flags are not maintained from top to bottom after the first installation.	Fill the tank with the liquid, and unfilled the tank, so the float pass the chamber in one cycle, then the unit can work normally.
	Liquid level rising speed too fast >1cm/sec	Contact the local sales.
Bi-colored flags rotate wrong side.	Flags installed with the wrong direction (Opposite up and down).	Reverse the flag display, green flag should be above the red one.
	Float installed in the wrong direction.	Re-installed the float, follow the mark "up" on the float.
Flags rotate 360° without reflect the actual level.	Float installed in the wrong direction.	Re-installed the float, follow the mark "up" on the float.
	Damaged magnet in the float, misplace the magnetic pole.	Float has to be replaced.
Magnetic switch abnormal.	Switch is not in the magnetic field.	Adjust the switch to the magnetic field.
	Strap may be found loose, switch is not in the magnetic field.	Adjust the switch to the magnetic field and fasten the straps.
	Magnetic switch is not trigger correctly with the liquid.	Fill the tank with the liquid, and unfilled the tank, so the float pass the chamber in one cycle, then the unit can work normally.
	Overloaded reed switch, damaged the contact	Change the circuit to the relay output.
Transmitter remains > 20mA	Strap may be found loose or chamber is bending out of the magnetic field.	Straighten and fasten the straps, or change a new transmitter.
Transmitter signal is abnormal without logic.	Device does not powered or wiring malfunction.	Check the wiring and re-start the power.
	Insufficient power, long transmitting distance or overloaded equipment.	Shorten the wiring or have power extension.
	Setting error of the end device.	Correct the setting: input/output, both setting should be the same.
	Interfere by conditions, inverters or electromagnetic field	Do not be in the same circuit with nverters.

※If abnormal is not listed above or cannot be eliminated, please contact local sales.

BEFORE USING / OPEN CHECK

1. Please check the packing situation.
2. Please contact us while finding any problem.
3. Please check the content:
 - a). Complete product x 1 set
 - b). Operation Manual x1 pc
 - c). Quality Approval x 1 pc



FineTek Co., Ltd.

No.16, Tzuchiang St., Tucheng Industrial Park, New Taipei City 23678, Taiwan.
Tel: 886-2-22696789 Fax: 886-2-22686682
Email: info@fine-tek.com http://www.fine-tek.com



08-EFXX-B2-EM,07/31/2018

