



Instruction Manual



DP-65



DP-500

The following instruction manuals are enclosed:

- AMM Limit Switch Instruction manual
- AMD Limit Switch Instruction manual
- TKEK Transmitter Instruction manual
- TEH, TTEH Transmitters Instruction manual
- THX, TTHX Transmitters Instruction manual
- TP-1200 Pneumatic Transmitter Instruction manual

Technical data

- Accuracy: DP-65: $\pm 2,5\%$ of full scale value.
DP-500: $\pm 4\%$ of full scale value.
- Rangeability: 10:1
- Scale length: ~ 100 mm.
- Scales: Direct according to fluid to be measured or in %.
- Mounting: Vertical:
Rising fluid flow. (BD)
Falling fluid flow. (DAB)
Horizontal:
Right to left fluid flow (DES)
Left to right fluid flow. (ED)
- Pipe Fittings: DP-65 Between flanges .
DP-500 Flanges DIN 2501.
Others on demand
- Materials: Polyamide 11 coated iron,
EN 1.4404 (AISI 316L).
- Working pressure: PN40 DN-40...DN-80
PN16 DN-100...DN-200
PN10 DN-250...DN-500
Others on demand.
- Fluid working temperature:
Standard:
- Polyamide-coated iron: $-20^{\circ}\text{C}...+90^{\circ}\text{C}$.
- EN 1.4404 (AISI 316L): $-50^{\circ}\text{C}...+130^{\circ}\text{C}$.
Special:
- EN 1.4404 (AISI 316L): up to $+300^{\circ}\text{C}$.
- Indicator Housing:
IP-65 Polyamide 11 covered aluminium.
- Mounting length:
DP-65:
65 mm DN-40...DN-300
DP-500:
500 mm DN-250...DN-300
600 mm DN-350...DN-400
700 mm DN-500

- Conforms with the Pressure Equipment Directive 97/23/CE.



This equipment is considered as being a pressure accessory and **NOT** a safety accessory as defined in the 97/23/CE directive, Article 1, paragraph 2.1.3.



- Optional Limit switches:
 - DP-AMM
Micro-switch mounted inside meter indicator housing.
Maximum current: 3A.
Maximum Voltage: 250 Vac.

Conforms with Directive 73/23/CEE (Low Voltage)



- DP-AMD
Slot type inductive limit switch according to norm DIN 19234 (NAMUR), mounted inside the meter indicator housing.

- Power supply: 8,2 Vdc

Conforms with Directive 89/336/CEE (EMC)



- Optional transmitters:
 - TKEX Angular position converter, coupled to the indicating system of the flow meter, which gives a linear output 0...4-20 mA proportional to the measured flow rate.
 - Power supply: 12,7...36 Vdc.
 - Output signal: 0...4-20 mA.
 - Electrical connection: 2, 3 ó 4 wire.
 - TEH A position transducer with analog output for 2 or 4 wire connection.
 - Power supply: 10 to 50 Vdc (2 wire) 220 Vac, 240 Vac, 110 Vac, 24 Vac 50/60 Hz (4 wire)
 - Output signal: 4-20 mA.

Certified by PTB to EEx ia IIC T6.
Conforms with Directives 73/23/CEE (Low voltage) and 89/336/CEE (EMC)



- TTEH A position transducer with analog output and totalizer for 2 or 4 wire connection.
 - Power supply: 10 to 50 Vdc (2 wire) 220 Vac, 240 Vac, 110 Vac, 24 Vac 50/60 Hz (4 wire)
 - Output signal: 4-20 mA.

Conforms with Directives 73/23/CEE (Low voltage) and 89/336/CEE (EMC)



- THX A position transducer with analog output for 2 wire connection.
 - Power supply: 10 to 24 Vdc
 - Output signal: 4-20 mA.

Conforms with Directives 89/336/CEE (EMC) and 94/9/CE (ATEX)



Certified by LOM to EEx ia IIC T4

- TTHX A position transducer with analog output and totalizer for 2 wire connection.
 - Power supply: 10 to 24 Vdc
 - Output signal: 4-20 mA.

Conforms with Directives 89/336/CEE (EMC) and 94/9/CE (ATEX)



Certified by LOM to EEx ia IIC T4TTHX

- TP1200

Pneumatic transmitter that gives an output of 3-15 psi or 0,2-1 bar proportional to the measured flow rate.

- Air supply: 1,4 bar $\pm 0,1$ bar

Dimensions DP-65

DN-40 to DN-300

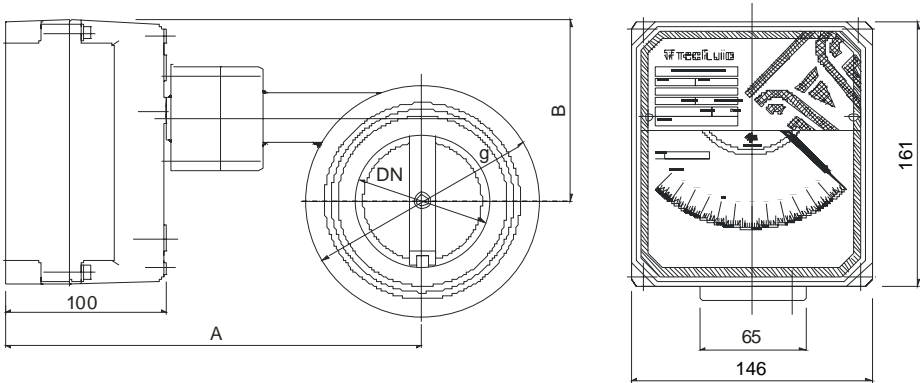

DN	A	B	g
40	255	74	95
50	255	79	109
65	255	86	128
80	255	96	141
100	255	106	158
125	283	116	191
150	283	124	220
200	326	148	271
250	351	133	322
300	363	151	378

Dimensions DP-500

DN-250 to DN-500

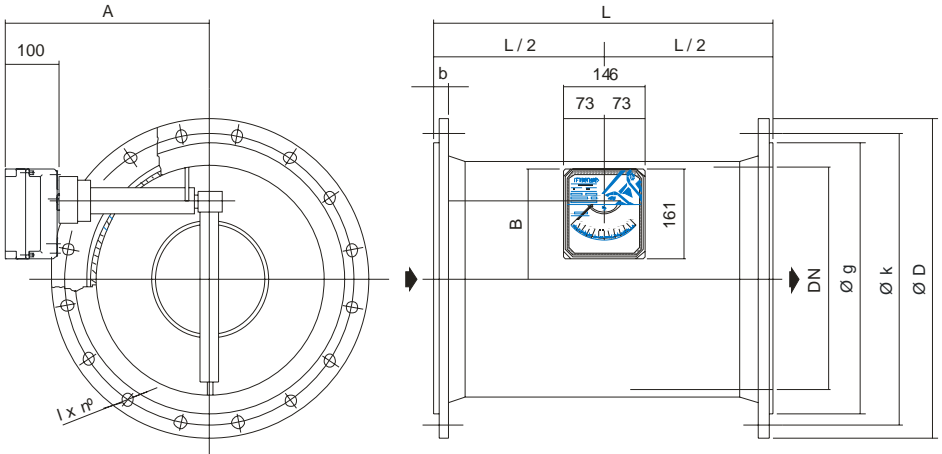

DN	L	A	B	D	K	g	b	l x No
250	500	351	90	395	350	320	26	22 x 12
300	500	363	115	445	400	370	26	22 x 12
350	600	353	124	505	460	430	26	22 x 16
400	600	353	142	565	515	482	26	26 x 16
500	700	403	180	670	620	585	28	26 x 20

Operation

The flow of a fluid through the flow meter, moves the target disk with a force which is proportional to the speed (flow rate).

The equilibrium point between the force the fluid exercises on the disk and the resistance of the torsion of the spring mounted on the target disk shaft determines the reading point

The corresponding flow rate reading is given by an indicator needle magnetically coupled to the target disk shaft.

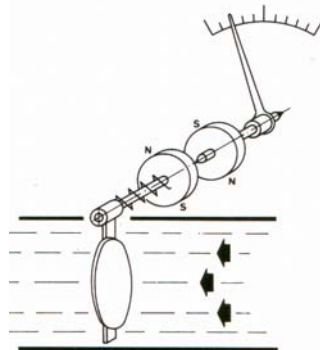

RECEPCIÓN

The DP-65 y DP-500 series flow meters are supplied already calibrated, ready to be mounted and put into operation.

The meters are supplied packed for their protection during haulage and storage. The target disk securing elements used for transport should be removed before mounting

The target disk must be checked manually to see if the spring shows an even resistance and that the indicator needle moves freely over the graduated scale and returns to 0.

MOUNTING THE FLOW METER

The MINIMAL distances of straight pipe, free of deviations, valves or elbow joints, BEFORE AND AFTER the meter must be respected. For liquids these distances are equivalent to 3 times the DN and for gases 8 times the DN.

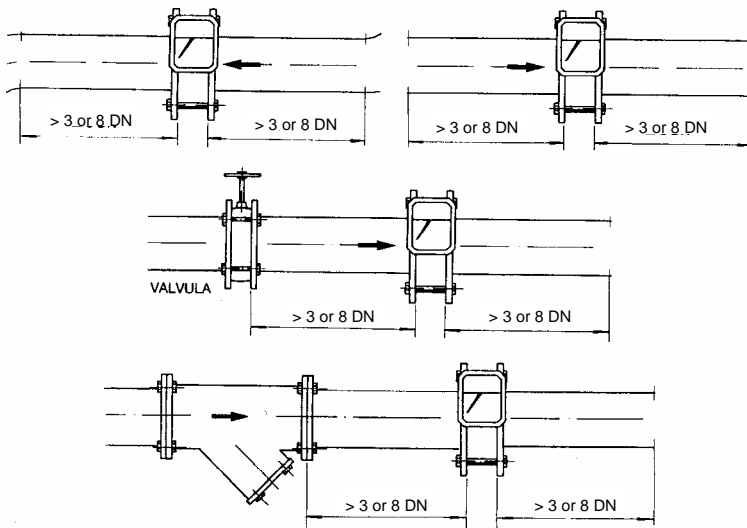

For the DP-65 series, up to DN-300, mounting must be done BETWEEN LOOSE FLANGES.

The DP-500 series, from DN-250 to DN-500, are supplied with fixed flanges.

The seal material should be suitable for the product. It is recommended that the seals have an internal diameter of about 5 to 10 mm greater than the nominal flow meter diameter. This will avoid reducing the free area or DN when tightening the flange screws, squeezing the seal. Any intrusion of the seals within the flow meter diameter can produce reading errors or interfere with the target disk movement. If the seal has the same internal diameter as the flow meter then it must be CAREFULLY CENTRED.

The flow direction should be the same as indicated on the scale plate. The following four flow directions are available:

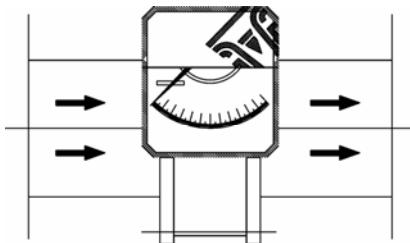
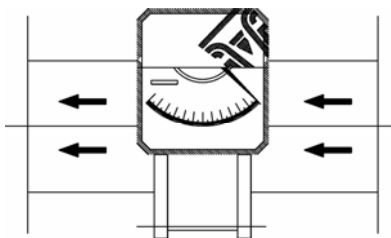
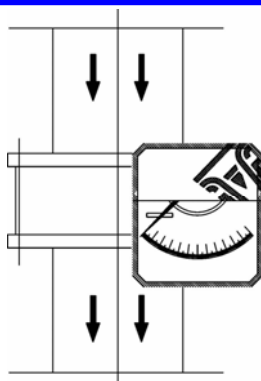
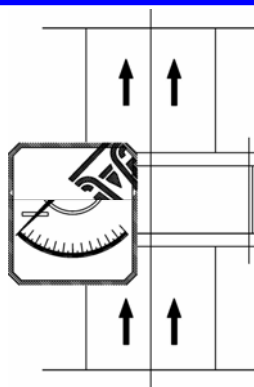
ED**DES****DAB****BD**

Mounting positions or flow directions different from those indicated on the scale plate can produce important reading errors or there will be no reading if the flow direction is in the opposite direction.

MECHANICAL MAINTENANCE

Indicator box

If operating anomalies are detected on meter reception then the following points should be checked. If necessary, remove the front cover that is held in place by four Allen screws, M5 (5) and the plastic washer (6), at the back of the indicator housing.

1. THE INDICATOR NEEDLE (1) IS RUBBING ON THE SCALE PLATE (4).

This normally happens if the meter is hit or dropped. Simply straighten it out by bending it slightly until it is separated by between 2-3 mm from the scale plate surface (4).

2. THE INDICATOR NEEDLE (1) DOESN'T READ 0 ON THE SCALE.

To check this the flow meter should be placed on a NON-MAGNETIC surface in its normal working position. If, when the target disk is moved the needle moves but does not return to 0, check that the bushing (3) is well fixed to the shaft (2). If this is not so, proceed to fix the bushing (3) to the conical end of the shaft using a careful and gentle blow.

It could have moved during transport or due to a blow from the flow meter being dropped. Adjust the indicating needle to the zero of the scale using the indicating needle's adjusting screw (7), turning left or right as required. Attention, hold the shaft (2) so that it will not be bent or damaged.

Check that there is no contact between the mobile system of the needle and connecting cables for limit switches or transmitters.

The flow meter will be properly adjusted to give correct readings.

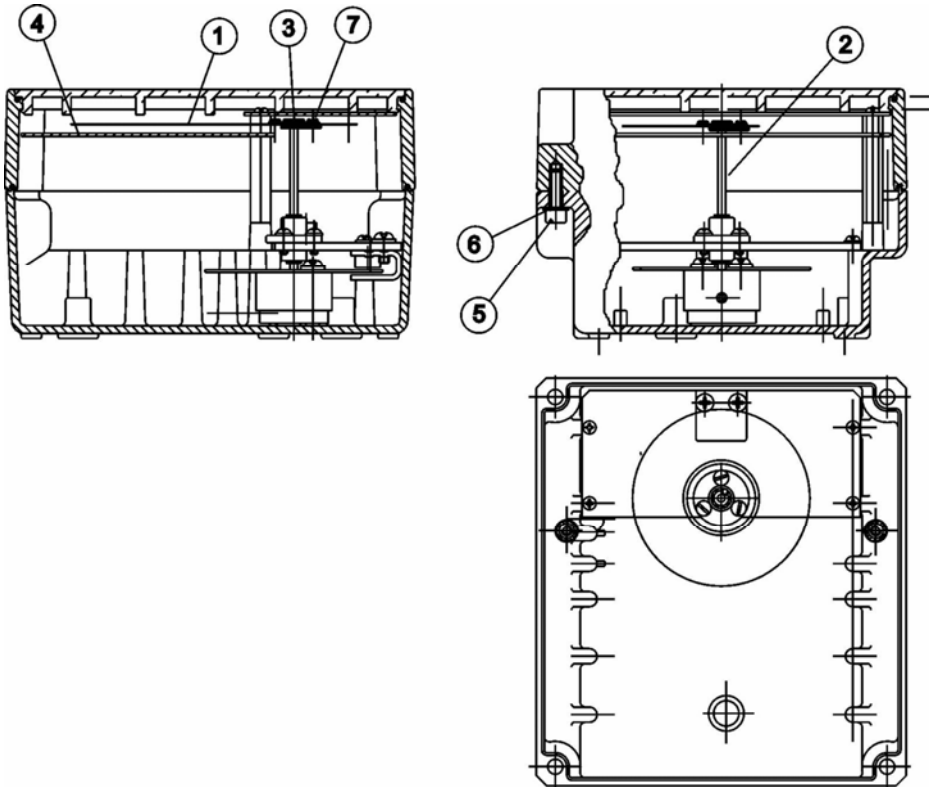

Flow meter body

The following faults may be appear in the flow meter body:

- Coupling magnet deterioration,
- Deterioration of the torsion or reading spring,
- Wearing out of torsion shaft bearings,
- Wearing out or deterioration of the lever and target disk.

If any of these breakdowns occur it is preferable to repair it in TECFLUID, S.A. workshops, given that normally a new calibration will be necessary.

CLEANING

Inline

Pass the normal cleanser through the installation.

In the workshop

Use soft brushes, never use sharp objects or metal brushes.

WARRANTY

Tecfluid S.A. GUARANTEES ALL ITS PRODUCTS FOR A PERIOD OF 24 MONTHS, after consignment, against all defects in materials and workmanship.

This warranty does not cover failures which can be imputed to misuse, use in an application different to that specified in the order, the result of service or modification by un-authorized persons, bad handling or accident.

This warranty is limited to cover the repair or replacement defective parts which have not been damaged by misuse.

This warranty is limited to the repair of the equipment and all further and eventually following damages are not covered by this warranty.

Any consignment of equipment to our factory or distributor must be previously authorised. The consignment should be done with the equipment well packed, clean of any liquids, grease or hazardous materials. Tecfluid S.A. will not accept any responsibility for damage done during transport.

Together with the equipment, a note should be enclosed indicating the failure observed, the name, address and telephone number of the sender.

TECFLUID, S.A.
Narcís Monturiol, 33
E-08960 Sant Just Desvern
Tel. + 34 933 724 511 - Fax + 34 934 734 449
E-mail: tecfluid@tecfluid.com
Internet: www.tecfluid.com

The technical data in this pamphlet is subject to modification without notification, if the technical innovations in the product or manufacturing processes so require.