



Spectra 10 Series Pressure Switch



UNITED ELECTRIC CONTROLS Installation and Maintenance Instructions

Please read all instructional literature carefully and thoroughly before starting. Refer to the final page for the listing of Recommended Practices, Liabilities and Warranties.

GENERAL



BEFORE INSTALLING, CHECK THE SENSOR MODEL SELECTED FOR COMPATIBILITY TO THE PROCESS MEDIA IN CONTACT WITH THE SENSOR AND WETTED PARTS.

The Spectra-10 pressure switch utilizes a diaphragm or piston sensor to detect a pressure change. The response, at a predetermined set point, actuates a SPDT snap-acting switch, converting a pressure signal into an electrical signal. Control set point may be varied by turning the internal slotted adjustment screw bushing according to procedures outlined in this document.

Part I - Installation

Tools Needed

1-1/16" Open end wrench
Screwdriver for customer-supplied mounting screws
(option M449 only)

MOUNTING



ALWAYS LOCATE UNITS WHERE SHOCK, VIBRATION AND AMBIENT TEMPERATURE FLUCTUATIONS ARE MINIMAL. DO NOT MOUNT IN AMBIENT TEMPERATURE AREAS EXCEEDING 160° F (WITH BUNA N CONSTRUCTION) OR 180°F (WITH VITON CONSTRUCTION). IF SEVERE PRESSURE SURGES ARE EXPECTED, CONSIDER THE USE OF A PRESSURE SNUBBER.



MOUNT USING PRESSURE CONNECTION: ALWAYS USE A WRENCH ON PRESSURE CONNECTION WRENCH FLATS. UNIT MAY BE MOUNTED IN ANY POSITION. HOWEVER, IF INSTALLATION LOCATION RESULTS IN FREQUENT EXPOSURE TO LIQUID, IT IS RECOMMENDED THAT THE UNIT BE MOUNTED VERTICALLY WITH THE PRESSURE CONNECTION DOWN. IF UNIT IS TO BE SET AFTER MOUNTING, RAISE ADJUSTMENT COVER, THEN THREAD IN PRESSURE CONNECTION UNTIL SNUG. VERIFY THAT ADJUSTMENT OPENING IS ACCESSIBLE.

1/2" NPT Electrical Connection (termination type C)

Mount through 7/8" clearance hole in panel. Hold in place with serrated 1/2" conduit nut. Always support the unit by holding a wrench on the 1-1/16" hex nearest the conduit connection.

Optional Surface Mounting Bracket (option M449)

The surface mounting bracket is a "C" style clamp with a single clearance hole to accommodate a 1/4" screw. Insert the unit into the bracket, pressure connection end first. Open the adjustment cover and mount the unit so that adjustment opening will be accessible when the switch is mounted. Close the adjustment cover ensuring that the bracket does not interfere with the cover. Failure to do so may result in improper sealing of adjustment cover. Mount assembly in desired location.

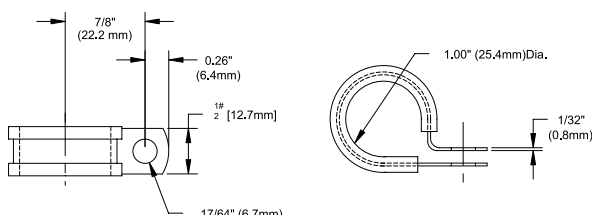

WIRING



DISCONNECT ALL SUPPLY CIRCUITS BEFORE WIRING UNIT. ELECTRICAL RATINGS STATED IN LITERATURE AND ON NAMEPLATES MUST NOT BE EXCEEDED. OVERLOAD ON A SWITCH CAN CAUSE FAILURE ON THE FIRST CYCLE.



WIRE IN ACCORDANCE WITH LOCAL AND NATIONAL ELECTRICAL CODES.

Termination Type A, 0.11" push-on terminals

Unit is supplied with male and female terminals. Insert 18-22 AWG stripped leadwire into female terminal and crimp using appropriate hand tool. Refer to molded-in N.O., N.C., and COM designations for proper wiring.

Termination Type B, 0.25" push-on terminals

N.O., N.C., and COM terminals require 1/4" female push-on terminals. Insulated female terminals are recommended for safety. Use non-conductive protective grease for corrosion resistance in outdoor use.

Termination Type C & D, 18" leads 18 AWG

Color coding:

TERMINALS	COLOR
N.O.	Blue
N.C.	Black
COM	Violet



TO ATTACH TYPE C TO CONDUIT CONNECTION, HOLD ELECTRICAL CONNECTION STEADY WITH WRENCH ON HEX, THEN THREAD ON CONDUIT.

Termination Type E, 1/2 NPT with 5' cord

Cut cord to desired length. Strip back insulation. Color coding:

TERMINALS	COLOR
N.O.	Red
N.C.	Black
COM	White



TO ATTACH TYPE E TO CONDUIT CONNECTION, HOLD ELECTRICAL CONNECTION STEADY WITH WRENCH ON HEX, THEN THREAD IN CONDUIT.

Termination Type F, DIN Connector with 4 Male Terminals

Connector conforms to DIN 43650. Use a mating DIN connector (female type). Coding:

TERMINALS	
Terminal #1	Common
Terminal #2	Normally Closed
Terminal #3	Normally Open
Terminal #4	Not used

Termination Type G, 5' cord

Cut cord to desired length. Strip back insulation. Color coding:

TERMINALS	COLOR
N.O.	Red
N.C.	Black
COM	White

Part II - Adjustments

Tools Needed
Screwdriver

1. Connect control to pressure source.
2. With power disconnected, slide cover toward electrical terminations while twisting it to overcome friction.
3. Connect power to terminals or leads.
4. Insert screwdriver into adjustment slot and turn left to increase setting or right to decrease setting.

For setting on rise, apply desired pressure and turn adjustment left until switch clicks (circuit across N.O. and COM terminals closes). For setting on fall, apply pressure equal to normal system operating pressure. Reduce source pressure to setpoint value. Turn adjustment right until switch clicks (circuit across N.C. and COM closes).

5. After completing adjustments, slide cover closed over adjustment compartment. Recheck set point.

Dimensions

Dimension A

	Diaphragm	Piston
	Model 10-12	Model 13-16
10-A	3" 76.2 mm	3.31" 84.1 mm
10-B	3.5" 88.9 mm	3.81" 96.8 mm
10-C	4.06" 103.2 mm	4.38" 111.1 mm
10-D	3.19" 81.0 mm	3.5" 88.9 mm
10-E	3.9" 100 mm	4.25" 108 mm
10-F	4.13" 104.8 mm	4.44" 112.7 mm
10-G	3.88" 98.4 mm	4.19" 106.4 mm

Dimension B

Model 10-12: 1/8 NPT
Model 13-16: 1/4 NPT

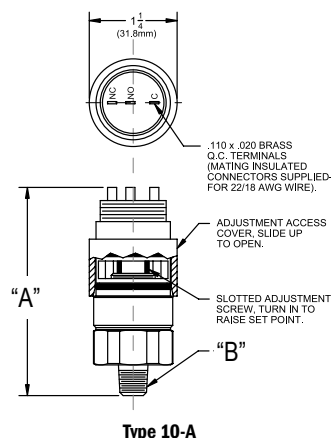

Type 10-A

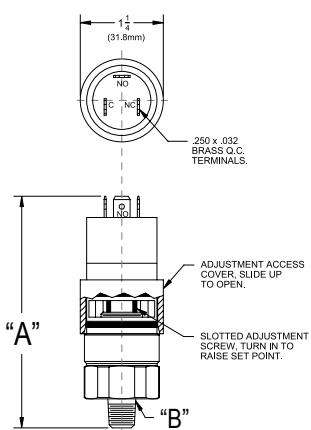

Type 10-B

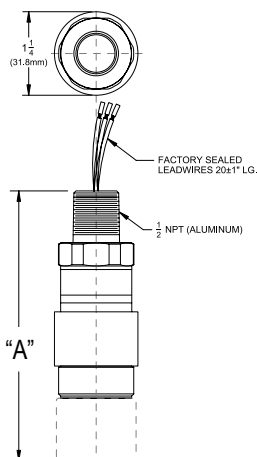

Type 10-C

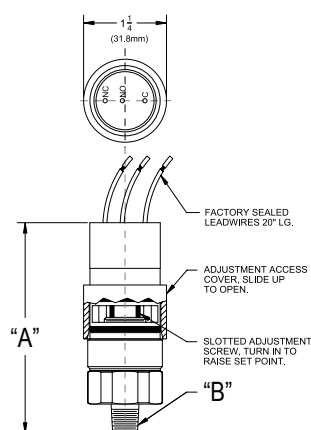

Type 10-D

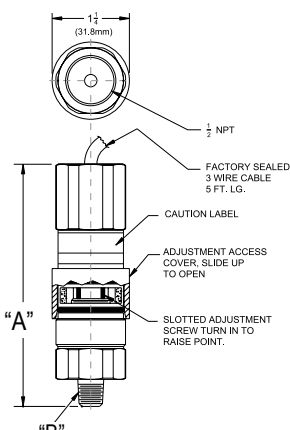

Type 10-E

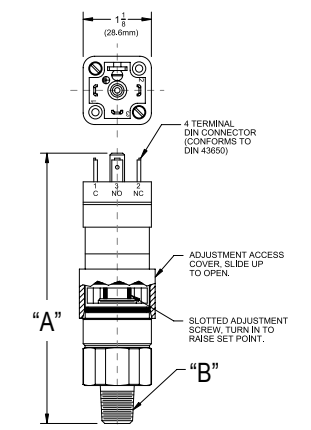

Type 10-F

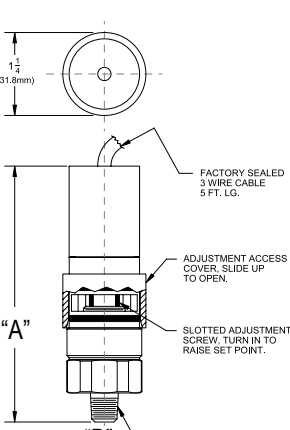

Type 10-G

RECOMMENDED PRACTICES AND WARNINGS

United Electric Controls Company recommends careful consideration of the following factors when specifying and installing UE pressure and temperature units. Before installing a unit, the Installation and Maintenance instructions provided with unit must be read and understood.

- To avoid damaging unit, proof pressure and maximum temperature limits stated in literature and on nameplates must never be exceeded, even by surges in the system. Operation of the unit up to maximum pressure or temperature is acceptable on a limited basis (e.g., start-up, testing) but continuous operation must be restricted to the designated adjustable range. Excessive cycling at maximum pressure or temperature limits could reduce sensor life.
- A back-up unit is necessary for applications where damage to a primary unit could endanger life, limb or property. A high or low limit switch is necessary for applications where a dangerous runaway condition could result.
- The adjustable range must be selected so that incorrect, inadvertent or malicious setting at any range point cannot result in an unsafe system condition.
- Install unit where shock, vibration and ambient temperature fluctuations will not damage unit or affect operation. Orient unit so that moisture does not enter the enclosure via the electrical connection. When appropriate, this entry point should be sealed to prevent moisture entry.
- Unit must not be altered or modified after shipment. Consult UE if modification is necessary.
- Monitor operation to observe warning signs of possible damage to unit, such as drift in set point or faulty display. Check unit immediately.
- Preventative maintenance and periodic testing is necessary for critical applications where damage could endanger property or personnel.
- For all applications, a factory set unit should be tested before use.
- Electrical ratings stated in literature and on nameplate must not be exceeded. Overload on a switch can cause damage, even on the first cycle. Wire unit according to local and national electrical codes, using wire size recommended in installation sheet.
- Do not mount unit in ambient temp. exceeding published limits.

LIMITED WARRANTY

Seller warrants that the product hereby purchased is, upon delivery, free from defects in material and workmanship and that any such product which is found to be defective in such workmanship or material will be repaired or replaced by Seller (Ex-works, Factory, Watertown, Massachusetts, INCOTERMS); provided, however, that this warranty applies only to equipment found to be so defective within a period of 24 months from the date of manufacture by the Seller. Seller shall not be obligated under this warranty for alleged defects which examination discloses are due to tampering, misuse, neglect, improper storage, and in any case where products are disassembled by anyone other than authorized Seller's representatives. EXCEPT FOR THE LIMITED WARRANTY OF REPAIR AND REPLACEMENT STATED ABOVE, SELLER DISCLAIMS ALL WARRANTIES WHATSOEVER WITH RESPECT TO THE PRODUCT, INCLUDING ALL IMPLIED WARRANTIES OF MERCHANTABILITY OR FITNESS FOR ANY PARTICULAR PURPOSE.

LIMITATION OF SELLER'S LIABILITY

Seller's liability to Buyer for any loss or claim, including liability incurred in connection with (i) breach of any warranty whatsoever, expressed or implied, (ii) a breach of contract, (iii) a negligent act or acts (or negligent failure to act) committed by Seller, or (iv) an act for which strict liability will be imputed to seller, is limited to the "limited warranty" of repair and/or replacement as so stated in our warranty of product. In no event shall the Seller be liable for any special, indirect, consequential or other damages of a like general nature, including, without limitation, loss of profits or production, or loss or expenses of any nature incurred by the buyer or any third party.

UE specifications subject to change without notice.



UNITED ELECTRIC
CONTROLS

180 Dexter Ave. P.O. Box 9143, Watertown, MA 02472-9143 USA
617 926-1000 Fax 617 926-2568
www.ueonline.com