



## Users Manual



## TECHNICAL DATA

<b>Material:</b>	Fork: EN 1.4404 (AISI 316L). Others on demand. Housing: Polycarbonate.
<b>Pipe fittings:</b>	Threads G1 (BSP), 1 NPT. DIN 11851, Clamp ISO 2852.
<b>Models:</b>	24-250 Vac. Maximum load 350 mA. 2 wire connection with series load 12 - 55 Vdc. Maximum load 350 mA. 3 wire connection
<b>Switching time:</b>	> 1s
<b>Hysteresis:</b>	± 2 mm with H <sub>2</sub> O
<b>Working Limits:</b>	Viscosity. Up to 10.000 cSt Density. > 0,6 kg / l Process temperature (liquid). -30 a 120°C Ambient temperature. -20 a 70°C Standard pressure: PN 16
<b>Degree of Protection:</b>	IP65

Conforms with the Directives 73/23/CE & 89/336/CE  
Conforms with the Pressure Equipment Directive 97/23/CE



This equipment is considered as being a pressure accessory and **NOT** a safety accessory as defined in the 97/23/CE directive, Article 1, paragraph 2.1.3.

### Dimensions:

#### Sanitary Thread ( DIN 11851)

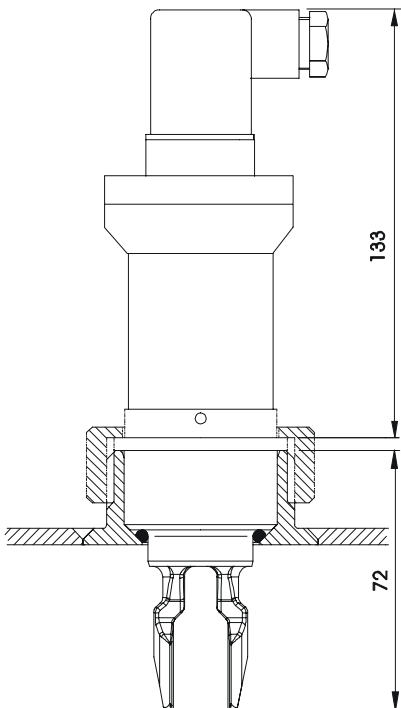

#### Clamp (ISO 2852)

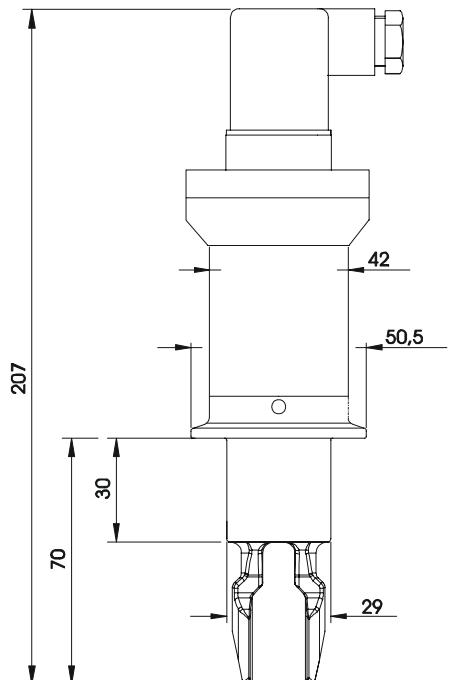

### G1 or 1 NPT Thread

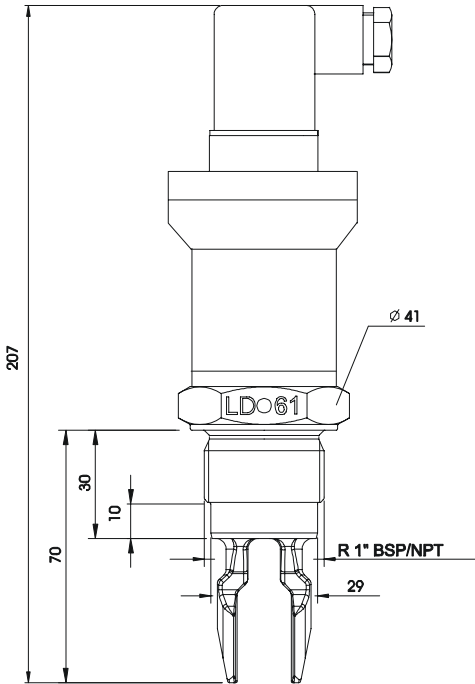

### LD-61 ML

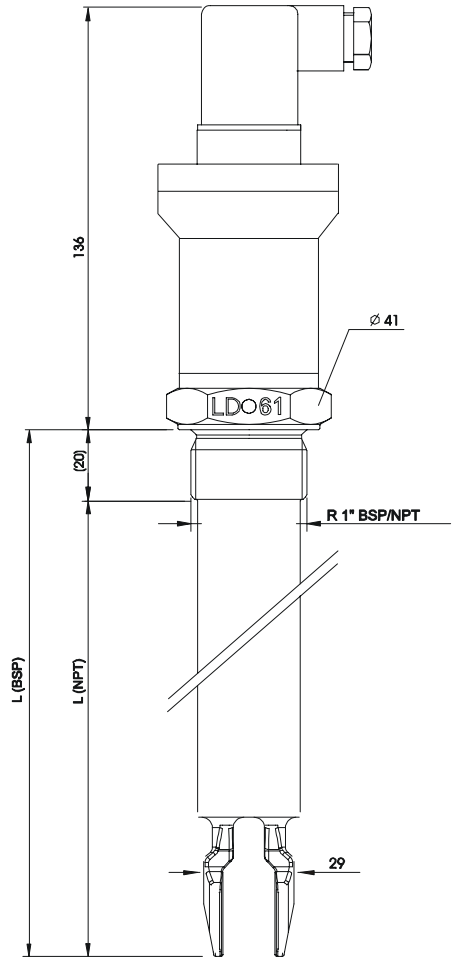

### WORKING PRINCIPLE

The LD-61 level switch is based on the variation of the natural resonant frequency of a vibrating fork, when it comes into contact with a liquid.

This variation is detected by the internal electronics and is used to determine the state of the output .

### RECEPTION

The LD-61 level detectors are supplied ready for installation and operation.  
They are supplied packed for their protection during storage and haulage.



To handle the detectors, they should always be held by the head, never by the vibrating fork.  
The vibrating fork should not be modified or bent, as this can damage the detector beyond repair.

## ELECTRICAL CONNECTION

The LD-61 can be installed as a detector of minimum or maximum level. The electrical connection is made by means of a DIN 43650-A connector with a PG-9 cable gland. Multiple conductor cable with sections about 0,5 mm<sup>2</sup> should be used.

To open the connector, remove the centre screw and prise open using a small screwdriver in the slot shown in the following drawing (looking at the female connector from the contact side).

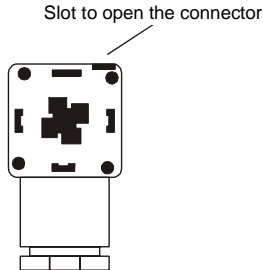

The working mode (maximum or minimum) is chosen by means of the cable connection, as shown in the following figure.

### a) DC version.



### b) AC version.

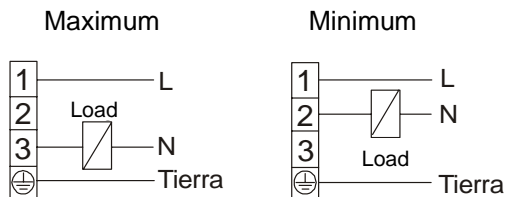

**NOTE:** The AC version has a power consumption of 6 mA when the load is deactivated. This should be taken into account when the load is a relay. You must make sure that the dropout voltage of the relay is greater than the voltage across the coil when a current of 6 mA flows through it. If the dropout voltage is equal or smaller then the relay can be in an activated position independent of the LD-61 state.

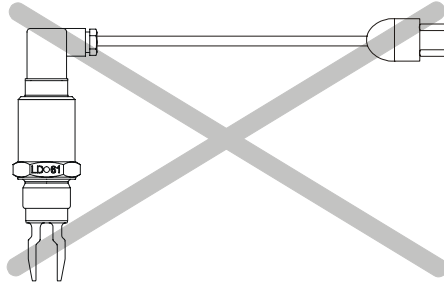

**With the AC version. the connection without a load will damage the instrument !**

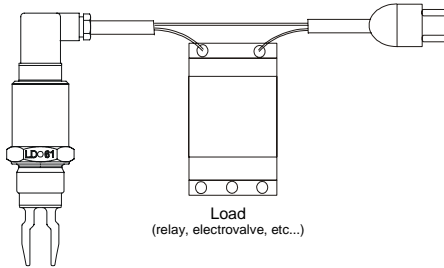

The LD-61 detector cannot be connected in series. Each detector must have its own load.

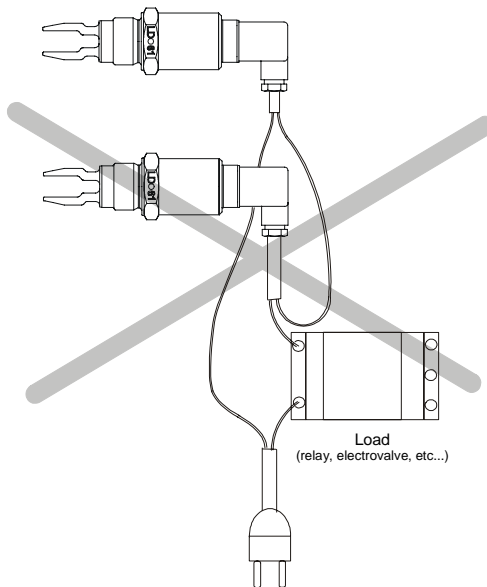

When the LD-61 is connected to detect a maximum level, the load is “activated” when the fork is not in contact with the fluid. In the same way, when the LD-61 is connected to detect a minimum level, the load is “activated” when the fork is in contact with the fluid.

The LD-61 has a bi-colour LED that indicates the state of the load “activated” (green colour) or “open” (red colour).

## MOUNTING

The LD-61 detector can be mounted in any position. The more usual insertion points are shown in the drawing.

In positions 1 the LD-61 acts as a maximum level detector. In positions 2 the LD-61 acts as a minimum level detector and in position 3 it acts as an empty pipe detector (for example, to protect a pump).

If the LD-61 is installed in a horizontal position it is recommended to install it with the tines vertical to avoid accumulation of substances, especially in the case of high viscosity materials.

To indicate the position of the tines the LD-61 has a round mark on two of the flats of the nut. These marks should be in a vertical position when the detector is installed in a horizontal position.

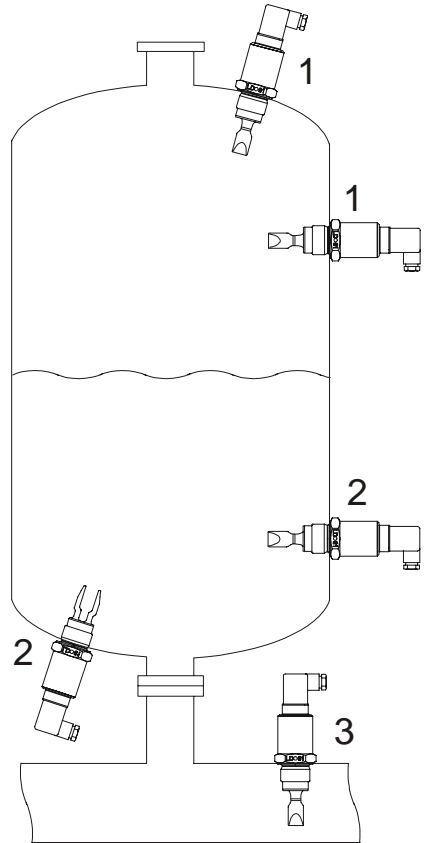
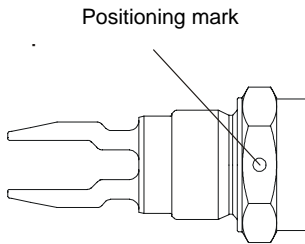

In the same way, when the detector is installed where there is flow, the position must be taken into account. The flat part of the tines must be aligned parallel with the flow direction.

If the viscosity is high, the tines must be kept away from other objects (such as the wall of the tank). In these cases it is preferable to install a longer detector.

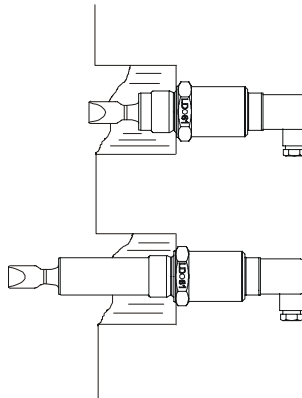

The cable gland should be situated on the lower side of the connector. If it is necessary, the position of the connector can be changed by 90° or 180°. To do this, open the connector and rotate. This operation must be done with the power disconnected

### OPERATION TEST

The operation of the installation can be checked by placing a magnet in the zone shown in the following figure. This magnet will change the output to the opposite state. In this way the correct installation of the instrument can be checked without having to change the level in the tank. At the same time, the bi-colour LED will indicate the change of state of the output.

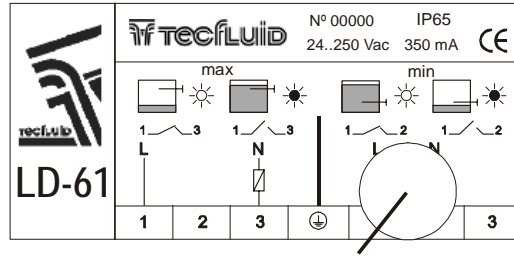

**Test zone**

### ACCESSORIES

An accessory that permits changing the length of the LD-61 which penetrates in the tank is available. This permits adjustment of the detection level.

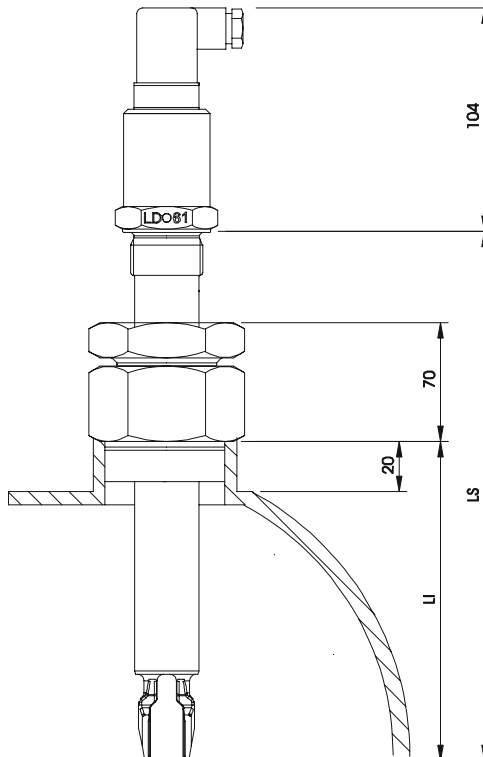

## **MAINTENANCE**

The life of the vibrating fork depends basically on the abrasive characteristics of the product used.

The LD-61 detector only needs maintenance when the product, which can adhere to the tines, will not let the detector change to a non detection state. In these cases the tines must be cleaned.

### **Cleaning**

To clean the tines, brush suitable for removing the incusted product, must be used . You should not try to knock off the adhered product from the tines.

During the cleaning process, be careful not to apply force against the tines as this can bend them and damage the detector beyond repair.

## **WARRANTY**

Tecfluid S.A. GUARANTEES ALL ITS PRODUCTS FOR A PERIOD OF 24 MONTHS, after consignment, against all defects in materials and workmanship.

This warranty does not cover failures which can be imputed to misuse, use in an application different to that specified in the order, the result of service or modification by un-authorized persons, bad handling or accident.

This warranty is limited to cover the repair or replacement defective parts which have not been damaged by misuse.

This warranty is limited to the repair of the equipment and all further and eventually following damages are not covered by this warranty.

Any consignment of equipment to our factory or distributor must be previously authorised. The consignment should be done with the equipment well packed, clean of any liquids, grease or hazardous materials. Tecfluid S.A. will not accept any responsibility for damage done during transport.

Together with the equipment, a note should be enclosed indicating the failure observed, the name, address and telephone number of the sender.

---

TECFLUID, S.A.  
Narcís Monturiol, 33  
E-08960 Sant Just Desvern  
Tel. + 34 93 3724511 - Fax + 34 93 4734449  
E-mail: [tecfluid@tecfluid.com](mailto:tecfluid@tecfluid.com)  
Internet: [www.tecfluid.com](http://www.tecfluid.com)