

## TEMPERATURE CONTROLLER



### 8400 8400 EXTENDED

Instruction Manual

© Bürkert 2000

Subject to technical change without notice

MAN 1000010386 ML Version: F Status: RL (released / freigegeben) printed: 19.08.2008

**bürkert**  
FLUID CONTROL SYSTEMS

# Table of contents

ENGLISH	<b>1 SAFETY RECOMMENDATIONS .....4</b>	<b>4</b>
	1.1 Utilisation.....4	4
	1.2 Precautions at installation and commissioning.....5	5
	1.3 Conformity to standards .....5	5
	<b>2 DESCRIPTION.....6</b>	<b>6</b>
	2.1 Design.....6	6
	2.2 Measuring principle .....6	6
	2.3 Available versions.....7	7
	2.4 Accessories.....7	7
	<b>3 TECHNICAL DATA .....8</b>	<b>8</b>
	<b>4 INSTALLATION .....12</b>	<b>12</b>
	4.1 General recommendations .....12	12
	4.2 Mounting on the pipe .....12	12
	4.3 Electrical connection .....13	13
	4.3.1 Cable plugs.....13	13
4.3.2 Version with transistor outputs (NPN and PNP).....14	14	
4.3.3 Version with relay output.....15	15	

**5 PROGRAMMING..... 16**

- 5.1 General recommendations .....16
- 5.2 Functionalities .....16
- 5.3 Programming keys .....17
- 5.4 Default Configuration.....17
- 5.5 Normal Mode .....18
- 5.6 Possible switching modes of the 8400 .....19
- 5.7 Calibration Mode.....20
- 5.8 Simulation Mode .....23

**6 MAINTENANCE..... 24**

- 6.1 Cleaning .....24
- 6.2 Error messages .....24

**7 ANNEX ..... 26**

- 7.1 Examples of connections with the 8400.....26
- 7.2 Description of the label of the controller.....29



**Always respect the safety instructions marked by the symbol opposite as well as those included in the manual.**

### 1.1 Utilisation

The 8400 or 8400 Extended controller has only been designed to measure the temperature of a liquid or a gas.

There will be no manufacturer warranty for damages caused by unexpected handling or wrong usage of the device. The warranty on the device becomes invalid if any modification or change is made on the device.



**The device should only be installed and repaired by specialist staff. The user is not allowed to work on the cables inside the housing. If any difficulties may occur with the product during installation, please contact your nearest Bürkert sales office for assistance.**

### 1.2 Precautions at installation and commissioning

- When the device is powered and the cover is open, protection against electric shocks is not ensured.
- Always ensure the materials in contact with the medium to measure are chemically compatible.
- To clean the device, only use chemically compatible products.
- Always protect the device from electromagnetic perturbations, ultraviolet radiations and, when installed outside, from the effects of climatic conditions.



- **When dismantling the controller from the pipe, take all the necessary precautions linked to the process.**
- **Always ensure the tightness between the controller and the pipe.**

### 1.3 Conformity to standards

EMC: EN 50 081-1, 50 082-2

Security: EN 61 010-1

Vibration: EN 60068-2-6

Shock: EN 60068-2-27

### 2.1 Design

The temperature controller 8400 or 8400 Extended is made up of an electronic module and a measuring element. It may switch a solenoid valve, activate an alarm or establish a control loop.

The switching point can be adjusted by means of the three keys located under the display. The adjustment can optionally be carried out by means of a 4-20 mA loop via an external controller.

The controller housing can be turned by 180°.

The electrical connection is carried out via an EN 175301-803 connector and/or a steerable M12 multipin connector.

### 2.2 Measuring principle

The controller uses a Pt100 measuring resistance.

The controller 8400 is fitted with a 46-mm long sensor.

The controller 8400 Extended is available with a 100-mm or a 200-mm long sensor.

### 2.3 Available versions

Power supply	Input (external setpoint)	Output	Electrical connection	Sensor length [mm]	Order code		
					G1/2	NPT1/2	Rc1/2
12-30 VDC	-	NPN and PNP	M12 connector	46	436501	436507	436504
12-30 VDC	-	Relays	M12 and EN 175301-803 connectors	46	436503	436509	436506
12-30 VDC	4-20 mA	Relays	M12 and EN 175301-803 connectors	46	440456	440460	440458
12-30 VDC	-	Relays	M12 and EN 175301-803 connectors	100	550053	-	-
12-30 VDC	-	Relays	M12 and EN 175301-803 connectors	200	550054	-	-

ENGLISH

ENGLISH

### 2.4 Accessories

Accessory	Order code
5-pin M12 cable plug, to be wired	917116
5-pin M12 cable plug, moulded on a shielded cable (2 m)	438680
EN175301-803 (type 2508) cable plug with cable gland	438811
EN175301-803 (type 2509) cable plug with NPT 1/2" reduction	162673

### 3 TECHNICAL DATA

### Temperature Controller 8400

#### General features

Pipe diameter	any type of pipe with a DN $\geq 15$ and a 1/2 " threaded connection piece (G, NPT or Rc)
Medium temperature	+125 °C max.
Fluid pressure max.	PN 16
Measuring range	-40 °C to +125 °C (with ambient temperature between 0 and +40 °C) -40 °C to +90 °C (with ambient temperature above +40 °C)

Switching accuracy	$\pm 0.5$ °C (0 to 80 °C) $\pm 1.5$ °C (outside 0 to 80 °C)
--------------------	--

Response time for a one step increment from 0 °C to 100 °C	7 s (10% to 90% of the increment)
--	-----------------------------------

Repeatability	0.4%
Sensor element	Pt100
Protection rating	IP 65, cable plugs being plugged-in and tightened

#### Electrical features

Installation class (overvoltage class)	2
Power supply	12-30 VDC

Current consumption	
Version with PNP output	max. 750 mA + consumption of the load, if the PNP output is connected max. 50 mA + consumption of the load, if the PNP output is not connected
Version with relay output	max. 80 mA, without load

Protection against polarity reversal	yes
--------------------------------------	-----

MAN 1000010386 ML Version: F Status: RL (released / freigegeben) printed: 19.08.2008

ENGLISH

ENGLISH

Transistor output	NPN and PNP, open collector, 700 mA max, NPN output: 0,2-30 VDC and PNP output: supply voltage (see example in the Annex)
or	
Relay output	250 VAC, 3 A max. or 30 VDC, 3 A max. ; programmable
External setpoint input	4-20 mA
Protection against short-circuits	yes for the transistor output
Type of cable recommended	shielded, wire section between 0.14 and 0.5 mm <sup>2</sup>

### Electrical connection

NPN/PNP version	5-pin M12 cable plug (not supplied)
Relay version	EN 175301-803 (supplied) <sup>1)</sup> and 5-pin M12 (not supplied) cable plugs

<sup>1)</sup>EaseOn with 2511 connector on request

### Materials

Housing	polycarbonate, fiber glass reinforced
Front plate	polyester
Parts in contact with the medium	stainless steel 316L (DIN 1.4404), FKM in the standard versions (EPDM as an option)

### Environment

Ambient temperature	0 to +60 °C (0 to +40 °C if fluid temperature may exceed +90 °C)
Relative humidity	< 80%, non condensated

### 3 TECHNICAL DATA

### Temperature Controller 8400

#### Dimensions (mm)

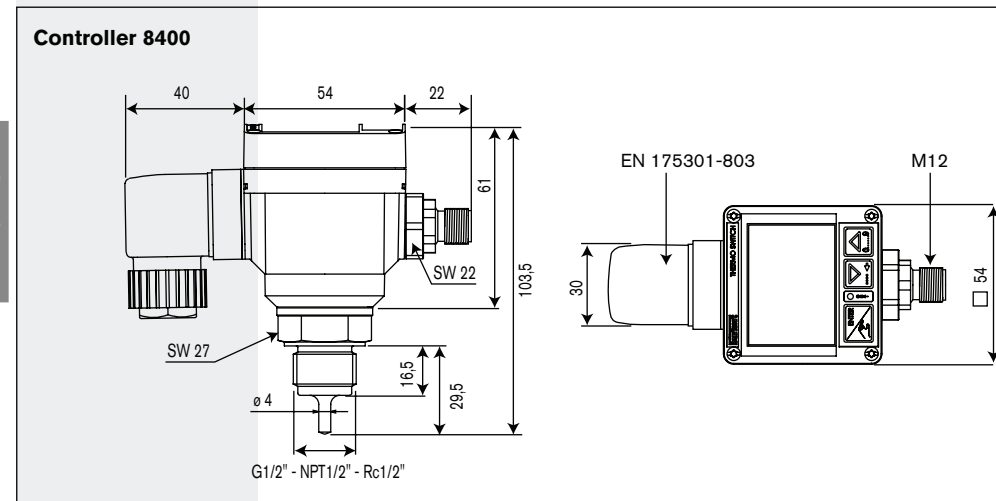

MAN 1000010386 ML Version: F Status: RL (released | freigegeben) printed: 19.08.2008

ENGLISH

**Controller 8400 Extended**

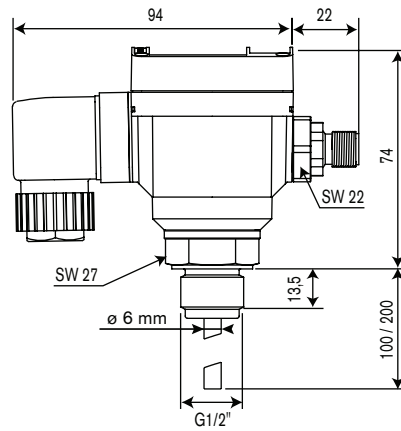

ENGLISH

#### 4.1 General recommendations



Always check the chemical compatibility of the materials the controller is made of with the products it may be in contact with, for instance: alcohols, strong or concentrated acids, aldehydes, bases, esters, aliphatics, aromatics, ketones, aromatics or halogenated hydrocarbons, oxidizing agents and chlorinated products.

For more information, please contact your Bürkert sales office.

#### 4.2 Mounting on the pipe

The controller 8400 can be inserted into a fitting before being installed onto a pipe.

During mounting, follow the instructions given with the fitting.

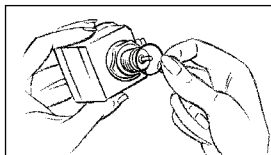

For G1/2"-version, ensure the gasket is in place

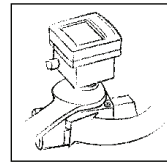

Do not tighten the controller using the housing; use an appropriate tool.



Ensure you do not unscrew the metallic part from the pipe, when you re-position the housing.

### 4.3 Electrical connection

Always ensure the power supply is switched off before working on the device. All the cable plugs must be plugged out. Use:

- a shielded cable with an operating temperature  $> +80\text{ °C}$ .
- a high quality voltage supply (filtered and regulated).



#### Install the following security devices:

- **for the power supply: a 1-A fuse**
- **for the relay: a 3-A fuse and a circuit breaker (depending on the application).**

#### 4.3.1 Cable plugs

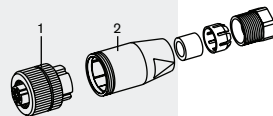

##### Multipin M12 cable plug (not supplied)

- Loosen threaded ring [1]
- Remove part [2] of the cable plug.
- Wire according to pin assignment (see 4.3.2 or 4.3.3)

##### Type 2508 cable plug (supplied)

- Unfasten screw [1].
- Remove part [3] from part [2].
- Unscrew cable gland [5].
- Insert cable into part [2] via cable gland.
- Wire part [3] (see 4.3.3)
- Replace part [3] into part [2], by 90°-steps.
- Tighten cable gland [5].
- Place gasket [4] between the cable plug and the fixed connector of the controller and plug the 2508 onto the fixed connector.
- Tighten screw [1] to ensure tightness and correct electrical contact.

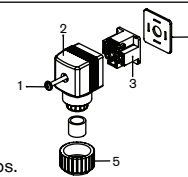

## 4 INSTALLATION

## Temperature Controller 8400

### 4.3.2 Version with transistor outputs (NPN and PNP)

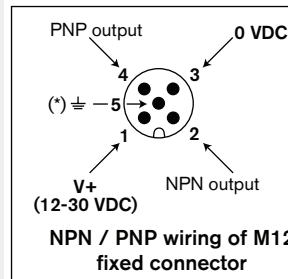
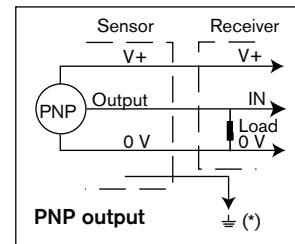
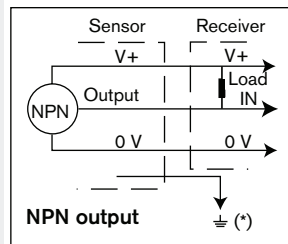

(\*) Functional earth

The controller is fitted with a steerable M12 fixed connector:

Unfasten counternut. Turn the fixed connector to the right position, but by max. 360° to avoid twisting of the cables inside the housing. Fasten counternut using the appropriate tool while maintaining the fixed connector in the right position.

Pin number of the M12 cable plug available as an accessory (order code 438680)	Wire colour
1	brown
2	white
3	blue
4	black
5	grey

### 4.3.3 Version with relay output

(\*) Functional earth

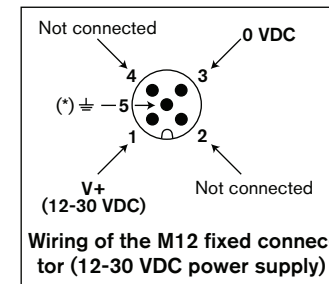
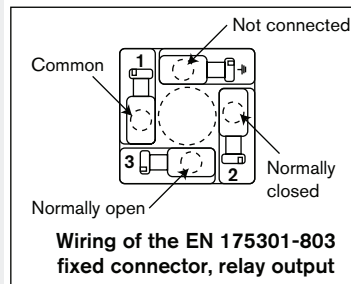

The controller is fitted with a steerable M12 fixed connector:  
Unfasten counternut. Turn fixed connector to the right position, but by max. 360° to avoid twisting cables inside the housing. Fasten counternut using appropriate tool while maintaining the fixed connector in the right position.

#### Operating safety

When the voltage at the relay terminals is higher than 24 V and the cable plugs are not correctly plugged-in and tightened, there is a risk to electrocute yourself.

Always check all the cable plugs before powering the device to ensure the good operating of the device.

### 5.1 General recommendations



Keep in mind that the process may be influenced by all the parameter settings you make. Fill-in the table on page 22 with your settings of the controller.

### 5.2 Functionalities

The device has three operating modes :

#### Normal Mode

Display of the measured temperature and the switching thresholds programmed. From the Normal mode, you can access the Calibration and Simulation modes.

#### Calibration Mode

Access to the programming of all the parameters (unit, output, filter, bargraph, temperature adjustment, extension board parameters). From the Calibration Mode, you can go back to the Normal Mode.

#### Simulation Mode

Entering a theoretical temperature value to test the configuration programmed in the Calibration Mode. You may also calibrate the optional extension board. From the Simulation Mode, you can go back to the Normal Mode.

### 5.3 Programming keys

To display the measured value and the configuration (8 characters: 4 numeric et 4 alphanumeric charact.)

To modify the digit value (0...9) ;  
To go back to the previous function.



To indicate the status of the switching output (red LED)

To validate a function;  
To validate the entered data.

To select the character;  
To go to the next function.

### 5.4 Default Configuration

At the first powering up, the configuration of the controller is as follows:

Temperature unit:	°C
Output:	hysteresis, inverted
OLO:	130 °C
OHI:	130 °C
DEL:	0 s
Filter:	2
BGLO:	0 °C
BGHI:	100 °C
Temperature adjust.	000.0
Extension board:	no

5.5 Normal Mode

Display of the measured temperature.  
 N.B.: When the units flash, the min. or max. value of the authorized range has been exceeded.

To go back to the previous function.

To display the high threshold value (O HI).

To go to the next function.

To display the low threshold value (O LO).

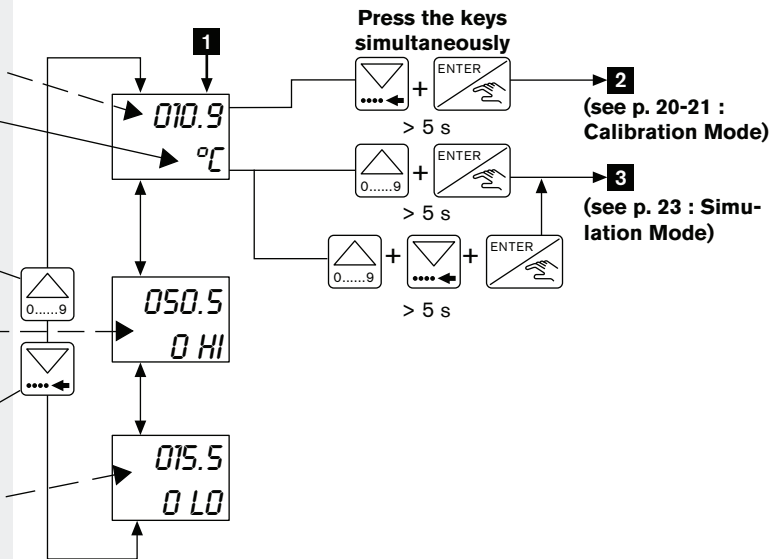

ENGLISH

ENGLISH

### 5.6 Possible switching modes of the 8400 Hysteresis Mode

The change of state occurs when a threshold is detected (increasing temperature: high threshold (OHI) to be detected, decreasing temperature: low threshold (OLO) to be detected).

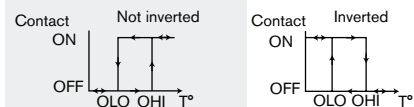

### Window Mode

The change of state occurs when any threshold is detected.

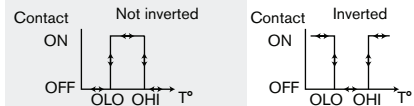

The delay (DEL) is set for both switching thresholds. The switching only occurs when either threshold value (OHI - OLO) is exceeded for a duration higher than the DEL delay.

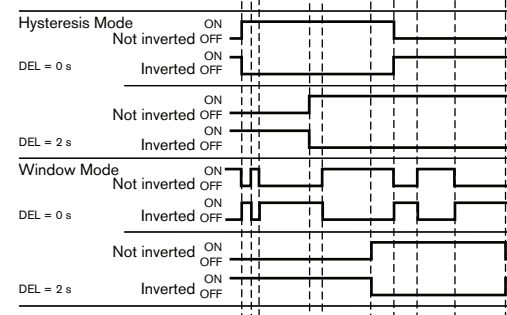
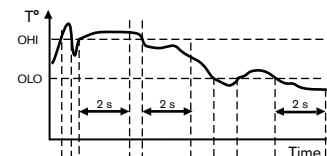

Switching examples of the 8400 depending on the temperature and the switching mode chosen

5.7 Calibration Mode

To change the temperature unit (°C or °F).

To go back to the previous function.

To go to the next function.

To choose :

- the switching mode of the output (Hysteresis or Window, see p. 19)
- the low (O LO) and high (O HI) switching thresholds
- whether the switching mode is inverted or not (INV, see p. 19)
- the delay before switching (DEL, in seconds).

To choose the filtering level (FLT) of the temperature displayed ONLY ; «0» means «all the temperature variations are displayed», «9» smoothes the displayed (only) temperature changes at the most.

MAN 1000010386 ML Version: F Status: RL (released / freigegeben) printed: 19.08.2008

**!** If you change the temperature unit, change the switching threshold values, too.

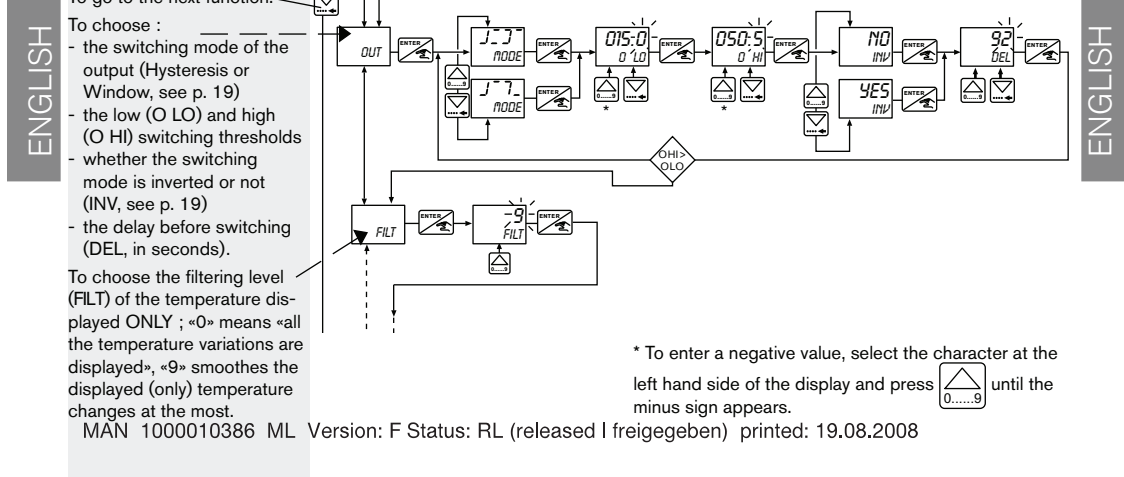

\* To enter a negative value, select the character at the left hand side of the display and press  until the minus sign appears.

ENGLISH

To define the min. (BG LO) and max. (BG HI) values of the bargraph at the bottom of the display.

To adjust the temperature (T°) in relation to the process.

To activate and calibrate the extension board (EXT).

To return (END) to the display of the temperature in the Normal mode.

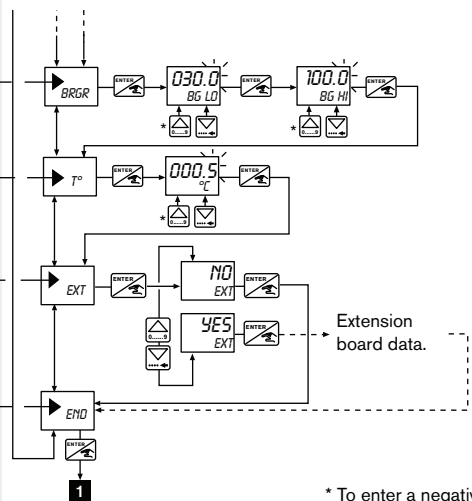

ENGLISH

\* To enter a negative value, select the character at the left hand side of the display and press  until the minus sign appears.

**5 PROGRAMMING**

**Temperature Controller 8400**

**Configuration of the 8400: complete the table with the values programmed within the Calibration mode.**

Unit	Mode		Thresholds		Inverted		Delay	Filtre	Bargraph		T° adjust.	Datum	Signature
UNIT	Hyst. <sup>1)</sup>	Win. <sup>2)</sup>	O LO	O HI	Yes	No	DEL (s)	FILT	BG LO	BG HI	T°		

ENGLISH

ENGLISH

**1) Hysteresis mode:**

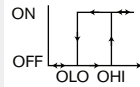

**2) Window mode:**



## 5.8 Simulation Mode

To calibrate the extension board (EXT) if present and activated (see Calibration mode).

To go back to the previous function.

To go to the next function.

To test the switching thresholds after entering a temperature value (SIM) and PRESSING THE ENTER KEY.

To return (END) to the display of the temperature in the Normal mode.

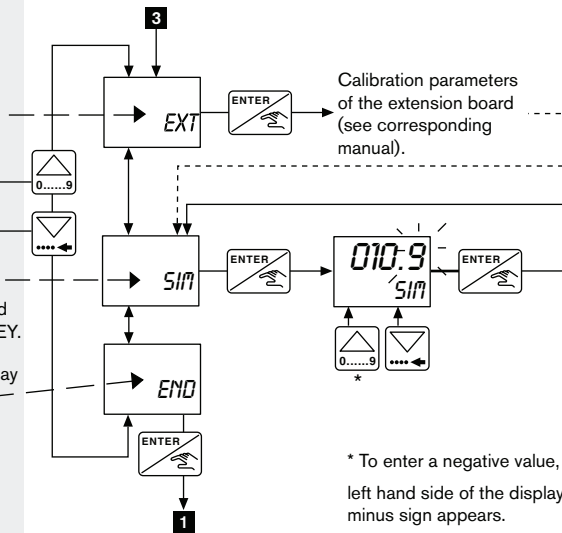

\* To enter a negative value, select the character at the left hand side of the display and press  until the minus sign appears.

**6.1 Cleaning**

The controller type 8400 can be cleaned with water or any solution compatible with the materials the device is made of.

For more information, please contact your Bürkert sales office.

**6.2 Error messages**

Displayed message	Signification	What to do
ERR 0	Calibration data is lost. Reading error: the process is stopped.	Press the ENTER key to go back to the Normal mode. The device has returned to its default configuration: the device must be calibrated again. If the message appears frequently, send the device back to your Bürkert sales office.
ERR 1	Calibration data cannot be saved. Write error: the process is stopped.	Press the ENTER key to go back to the Normal mode. The device displays the configured data; BUT this data has not been saved: the device must be calibrated again. If the message appears frequently, send the device back to your Bürkert sales office.
ERR 2	The calibration parameters cannot be accessed. Menu reading error: the process goes on operating.	Press the UP and DOWN keys under the display to scroll through the menus. If the message appears frequently, send the device back to your Bürkert sales office.

MAN 1000010386 ML Version: F Status: RL (released | freigegeben) printed: 19.08.2008

ENGLISH

Displayed message	Signification	What to do
ERR 4	The 8400 controller no more measures the temperature correctly: the process is stopped.	Switch the controller off than on again. If the message appears frequently, send the device back to your Bürkert sales office.
ERR 5	- the connection with the Pt100 sensor is lost. - The medium temperature is out of the authorized range ( $T^{\circ} \leq -50 \text{ }^{\circ}\text{C}$ , $-58 \text{ }^{\circ}\text{F}$ or $T^{\circ} \geq +170 \text{ }^{\circ}\text{C}$ , $+338 \text{ }^{\circ}\text{F}$ )	- Send the device back to your Bürkert sales office. - Check the temperature of the process.

ENGLISH

## 7.1 Examples of connections with the 8400

**NPN connection:  
controller type 8400  
(NPN/PNP version)  
and a Programmable  
Logic Controller.**

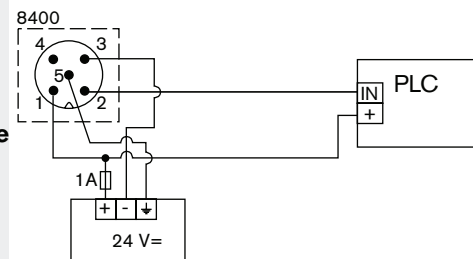

**PNP connection:  
controller type 8400  
(NPN/PNP version)  
and a Top Control  
type 8631.**

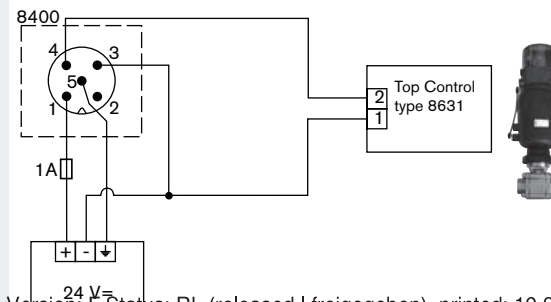

ENGLISH

**NPN connection:  
controller type 8400  
(NPN/PNP version)  
and a solenoid valve  
type 6014.**

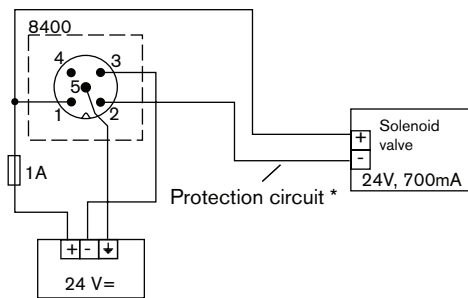

\* Protection must be installed by the user depending on the load, for instance, a connector EN 175301-803 with integrated varistor.

**PNP connection:  
controller type 8400  
(NPN/PNP version)  
and a solenoid  
valve.**

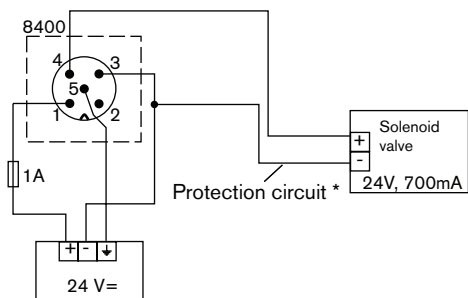

ENGLISH

**NO (Normally Open) connection: controller type 8400 (relay version) and a solenoid valve.**

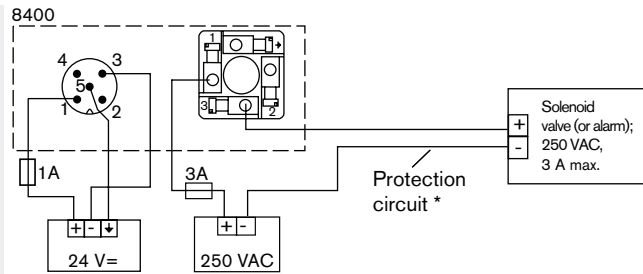

**NC (Normally Closed) connection: controller type 8400 (relay version) and a solenoid valve.**

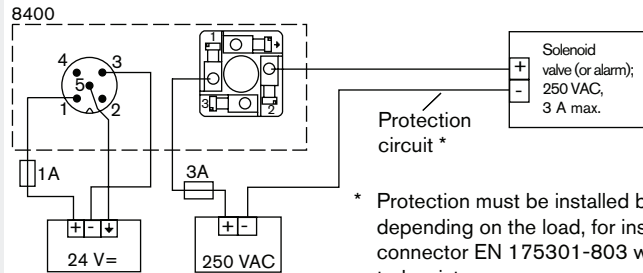

\* Protection must be installed by the user depending on the load, for instance, a connector EN 175301-803 with integrated varistor.

ENGLISH

ENGLISH

## 7.2 Description of the label of the controller

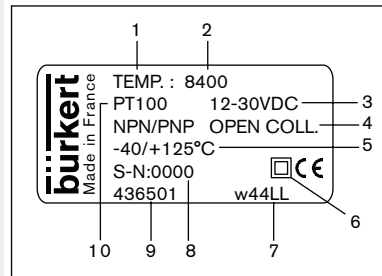

1. Measured quantity
2. Type of controller
3. Power supply
4. Output characteristics
5. Temperature range
6. Protection class : protective insulation
7. Manufacturer code
8. Serial number
9. Order number
10. Sensor type