

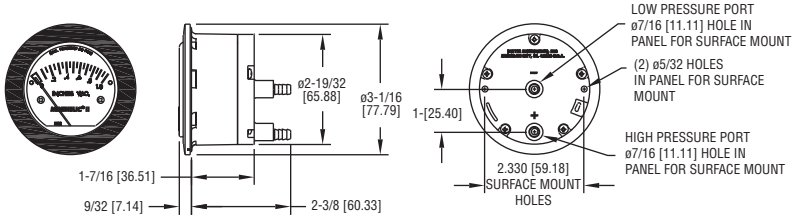

Series 2-5000 Minihelic® II Differential Pressure Gage

Specifications: Installation & Operating Instructions



Series 2-5000 Minihelic® II Differential Pressure Gages have clean design, small size, low cost and sufficient accuracy for all but the most demanding applications. With housing molded from mineral- and glass-filled nylon and a lens molded from polycarbonate, this gage will withstand rough use and exposure, as well as high total pressure up to 30 psig [2.067 bar]. Over-pressure is accommodated by a blow-out membrane molded in conjunction with the diaphragm.

INSTALLATION

1. Select a location free from excessive vibration and where ambient temperature will be between 20 to 120°F (-6.7 to 49°C). Sensing lines may be any length necessary without affecting accuracy. However, long runs of tubing will dampen readings slightly and cause a minor increase in response time. If pulsing pressure or vibration cause excessive pointer oscillation, please contact factory for ways to provide additional damping.

2. This gage is calibrated and zeroed in the vertical position at the factory. If the gage is used in any other position, it must be re-zeroed each time the position is changed. Gages with ranges under 5" w.c. (1.24 kPa), or the equivalent, should be used only in the vertical position unless special calibration was specified when ordering.

SPECIFICATIONS

Service: Air and compatible gases.

Wetted Materials: Consult factory.

Housing: Glass filled nylon; polycarbonate lens.

Accuracy: $\pm 5\%$ of full scale at 70°F (21.1°C).

Pressure Limits: 30 psig (2.067 bar) continuous to either pressure connection.

Temperature Limits: 20 to 120°F (-6.67 to 48.9°C).

Size: 2-1/16" (52.39 mm) diameter dial face.

Mounting Orientation: Diaphragm in vertical position. Consult factory for other position orientations.

Process Connections: Barbed, for 3/16" I.D. tubing (standard); 1/8" male NPT (optional).

Weight: 6 oz (170.1g).



CAUTION: FOR USE ONLY WITH AIR OR COMPATIBLE GASES.

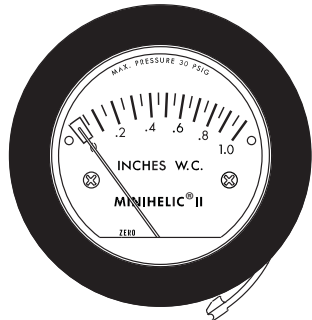
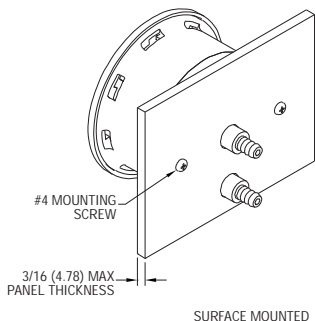
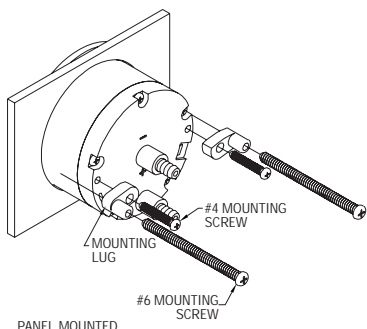

Figure A



PANEL MOUNTED INSTALLATION

3. To surface-mount the gage in a 3/16 (4.78 mm) max panel thickness, drill two 5/32" (3.97 mm) apart on a horizontal line, 2.330" (59.18 mm) apart for mounting screws. Next, drill two 7/16" (11.11 mm) holes 1.000" (25.4 mm) apart on a vertical line for pressure connections. Secure the gage with two #4 mounting screws. Be careful not to block the slotted hole near the right-hand mounting hole, this provides a path for pressure relief in the event of over-pressurization.

4. To panel-mount the gage, cut a 2-5/8" (66.68 mm) diameter hole. Install mounting lugs to the back of the gage with two #4 mounting screws, thread two #6 mounting screws through mounting lugs and tighten.

5. Before installation, the Minihelic® II Differential Pressure Gage may need to be zeroed before placing into operation. If zeroing is required perform the following steps as described. Pull out the integral locking clip approximately 1/4" located on the side of the cover bezel near the bottom face of the gage. See Figure A.



Caution: Do not exceed pulling the clip out further than 1/4" from bezel or damage to the integral clip will result.

The clip is integral to the bezel and will try to spring back into position; the hex allen wrench supplied can be placed between the clip and the bezel to keep the clip extended while removing the cover. Next, hold the case of the gage firmly with one hand and rotate the cover in the counterclockwise direction with the palm of the other hand. The cover will rotate approximately 9 degrees then begin lifting off of the housing. The cover can then be removed from the housing.



Caution: When removing the cover be careful to slowly pull the cover straight off the gage housing.

Damage can occur to the scale if the cover is pulled off on an angle. If difficult to loosen cover, place a small sheet of rubber between the cover and the palm of the hand. The zero adjust screw is located below the scale at the "zero" label near the base of the pointer. Use the hex allen wrench supplied and adjust until the pointer is on zero. This must be done with both pressure connections vented to atmosphere and the gage oriented in the final mounting position.

After zeroing the gage replace the cover by aligning the integral clip head with the notch in the case, press and rotate the cover clockwise until the clip head snaps into the slot.

6. To measure positive pressure, connect tubing to port marked "HI" and vent "LO" port to atmosphere. For negative pressure (vacuum), connect to port marked "LO" and vent "HI" port to atmosphere. For differential pressure, connect higher pressure to port marked "HI" and lower to "LO" port. If gage is supplied with 1/8" NPT connections, be careful not to over-tighten fittings to avoid damage to the gage.

CALIBRATION CHECK

Select a second gage or manometer of known accuracy and in an appropriate range. Use short lengths of rubber or vinyl tubing to connect the high-pressure side of the gage and the test gage to two legs of a tee. Very slowly, apply pressure through the third leg. Allow enough time for pressure to equalize throughout the system and for fluid to drain, if a manometer is being used. Compare readings. If the gage being tested exceeds rated accuracy, it should be returned to the factory for recalibration.

MAINTENANCE

No lubrication or periodic servicing is required. Keep case exterior and cover clean. Occasionally, disconnect pressure lines to vent both sides of the gage to atmosphere and re-zero per installation paragraph 5.

Upon final installation of the Series 2-5000 Minihelic® II Differential Pressure Gage, no routine maintenance is required. A periodic check of the system calibration is recommended. The Series 2-5000 is not field serviceable and should be returned if repair is needed (field repair should not be attempted and may void warranty). Be sure to include a brief description of the problem plus any relevant application notes. Contact customer service to receive a return goods authorization number before shipping.