



100 Series
Type H100
(Pressure Switch)

Type H100K
(Differential Pressure)



UNITED ELECTRIC
CONTROLS

**Installation and Maintenance
Instructions**

Please read all instructional literature carefully and thoroughly before starting. Refer to the final page for the listing of Recommended Practices, Liabilities and Warranties.

GENERAL



BEFORE INSTALLING, CHECK THE SENSOR MODEL SELECTED FOR COMPATIBILITY TO THE PROCESS MEDIA IN CONTACT WITH THE SENSOR AND WETTED PARTS.

The H100 and H100K differential pressure switches are activated when a bellows, diaphragm or piston sensor responds to a pressure change. This response, at a pre-determined set point, actuates a single snap-acting switch, converting the pressure signal into an electrical signal. Control set point may be varied by turning the internal adjustment hex. (See Adjustment -PART II).



PROOF PRESSURE* LIMITS STATED IN THE LITERATURE AND ON NAMEPLATES MUST NEVER BE EXCEEDED, EVEN BY SURGES IN THE SYSTEM. OCCASIONAL OPERATION OF UNIT UP TO PROOF PRESSURE IS ACCEPTABLE (E.G., START-UP, TESTING). CONTINUOUS OPERATION SHOULD NOT EXCEED THE DESIGNATED OVER RANGE PRESSURE.

*Proof Pressure

The maximum pressure to which a pressure sensor may be occasionally subjected, which causes no permanent damage (e.g., start-up, testing). The unit may require re-gapping.



THESE PRODUCTS DO NOT HAVE ANY FIELD REPLACEABLE PARTS.

Please refer to product bulletin for product specifications. Product bulletin may be found at www.ueonline.com.

Part I - Installation

Tools Needed

Adjustable Wrench
Screwdriver
Hammer (for alternate wire knockouts)

MOUNTING



INSTALL UNIT WHERE SHOCK, VIBRATION AND TEMPERATURE FLUCTUATIONS ARE MINIMAL. ORIENT UNIT SO THAT MOISTURE IS PREVENTED FROM ENTERING THE ENCLOSURE. IF

UNIT IS BEING INSTALLED WHERE HEAVY CONDENSATION IS EXPECTED, VERTICAL MOUNTING (PRESSURE CONNECTION DOWN) IS REQUIRED. DO NOT MOUNT IN AMBIENT TEMPERATURES EXCEEDING PUBLISHED LIMITS.

Controls may be mounted and operated in any position. They may be surface mounted via the two mounting ears on either side of the enclosure, or directly to a rigid pipe by using the pressure connection. Low pressure and differential pressure units, models 520-535, 540-543, 544-548, are also available with an optional surface mounting bracket. Should the control be installed where condensation is expected, vertical mounting is recommended as a means of keeping water away from switch terminals.

Never use the enclosure for leverage to hand tighten the pressure connection. Always use a wrench to tighten the pressure connection to the pipe. To prevent damaging the pressure sensor, use a back-up wrench to hold the hex nut in place when surface mounting.

On models supplied with an external manual reset button, be sure to leave sufficient finger space over the reset button for the operator to reset the control.

WIRING



DISCONNECT ALL SUPPLY CIRCUITS BEFORE WIRING.



ELECTRICAL RATINGS STATED IN LITERATURE AND ON NAMEPLATES SHOULD NEVER BE EXCEEDED. OVERLOAD ON A SWITCH CAN CAUSE FAILURE ON THE FIRST CYCLE.



WIRE UNITS ACCORDING TO NATIONAL AND LOCAL ELECTRICAL CODES. MAXIMUM RECOMMENDED WIRE SIZE IS 14 AWG.

Remove the two screws retaining the cover and cover gasket. A 1/2" NPT conduit connection is provided on the left hand side of the enclosure. Two cast-in knockouts for the 1/2" conduit are located on the side and back of the enclosure. These can easily be knocked out by placing the blade of a screwdriver in the groove and tapping sharply with a hammer. The three switch terminals are clearly labeled "common", "normally open" and "normally closed". For optional switches supplied with leadwires, the following color coding applies:

	Manual	DPDT	
Reset			
	(Option 1530)	(Option 1010)	
SPDT	SWT1	SWT2	
Common	Violet	Violet	Yellow
Normally Open	Blue	Blue	Orange
Normally Closed	Black	Black	Red

A grounding screw and clamp (cast in symbol) is provided which meets a 35 lb. pull test. Keep the wire as short as possible to prevent interference with the plunger and the optional adjustable differential switch wheel, if applicable.

Part II - Adjustments

Tools Needed

5/8" Open End Wrench
1/4" Wrench
3/16" Wrench



SOME MODELS HAVE A TWO-PIECE, ADJUSTABLE PLUNGER. THIS FEATURE IS CHARACTERIZED BY A 3/16" HEX HEAD SCREW INSTALLED IN THE 1/4" HEX PLUNGER. THE LENGTH OF THIS ASSEMBLY IS ADJUSTED AT OUR FACTORY AND IS CRITICAL TO THE FUNCTION OF THE CONTROL.

H100 and H100K

Remove pressure switch cover. Loosen Phillips screw adjustment lock. Adjust set point by turning 5/8" hex adjustment screw clockwise (left) to raise set point, or counter clockwise (right) to lower set point. Tension on adjustment screw can be increased by tightening adjustment lock onto it. (See diagram 1). Controls include uncalibrated reference scales for high, low or mid range settings.

Adjustable Differential Models

Model 15623, 15731-15737, and control types with option code 1519 incorporate a snap switch with internal adjustment wheel. Turning this wheel raises or lowers the pressure rise set point. The fall set point remains constant. Consult factory for additional information.

Manual Reset Button

Control types with option code 1530 incorporate a snap switch which when actuated, remains actuated until the pressure drops sufficiently to allow the reset button (located on top of the control) to be manually depressed to reset the switch.

Gapping

- 1) Loosen adjustment lock.
- 2) Turn 5/8" hex adjustment screw clockwise (left), to approximately mid range. This puts a load on the sensor and exposes the plunger flats. Using a 1/4" wrench on the plunger and a 3/16" wrench on the plunger hex screw, turn hex screw counter-clockwise (right) from plunger until switch actuates. If switch is already actuated, turn plunger hex screw clockwise (left), until switch deactuates. Turn hex screw clockwise (left) from this point. (See chart 1 for Flats and approximate Gap.)
- 3) Check set point per above.
- 4) Connect wires and replace cover securely.

Models	Flats	Approx. Gap
171-174	2-2 1/2	.0085 to .0105"
183-194	1-1 1/2	.004 to .006"
483-494	1-1 1/2	.004 to .006"
358-376	5-6	.020 to .025"
700-706	3 1/2 - 4	.014 to .017"
521-525	2-2 1/2	.0085 to .0105"
15737	5-6	.020 to .025"
531-535	2-2 1/2	.0085 to .0105"
540-548	2-2 1/2	.0085 to .0105"
560-567	1-1 1/2	.004 to .006"
15623	5-6	.020 to .025"
15731-15736	5-6	.020 to .025"

Chart 1

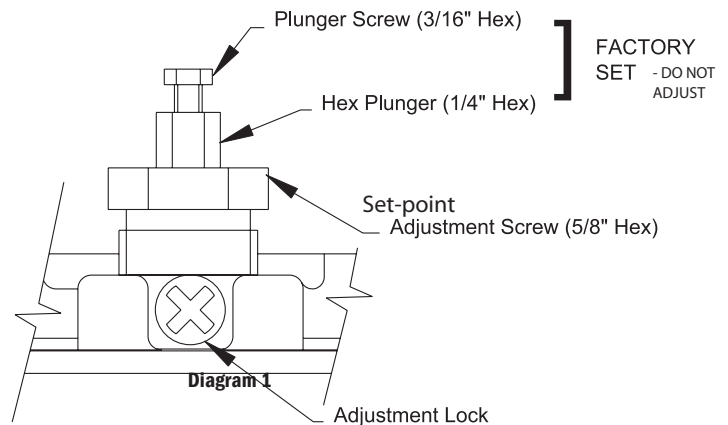

Dimensions

Dimensional drawings for all models may be found at www.ueonline.com.

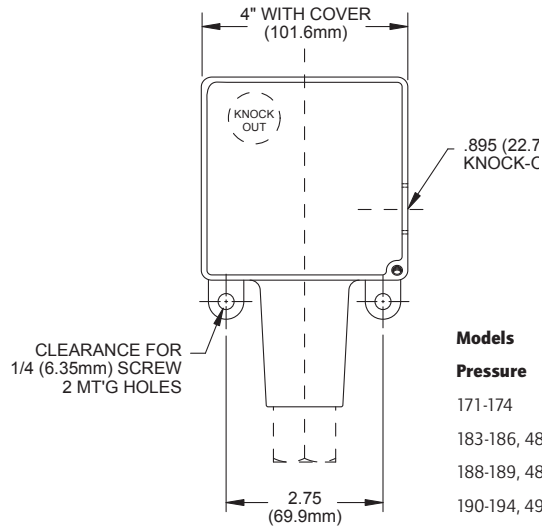
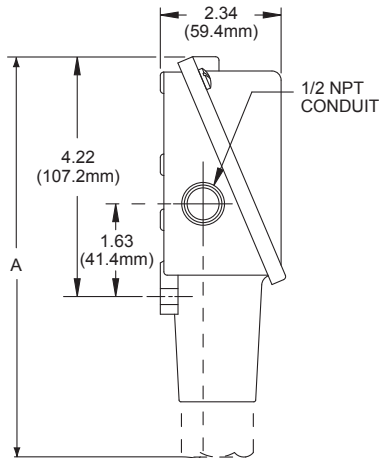

Models	Dimension A		
	Inches	mm	NPT
Pressure			
171-174	7.63	193.8	1/2"
183-186, 484-486	7.56	192.0	1/2"
188-189, 488-489	6.63	168.4	1/2"
190-194, 490-494	6.63	168.4	1/2"
218	6.56	166.6	1/4"
270-274	7.00	177.8	1/4"
358-376	7.00	177.8	1/4"
520-525, 15737	8.44	214.4	1/2"
530-535	8.00	203.2	1/2"
560-564	6.63	168.4	2" Sanitary Fitting
565-567	6.63	168.4	1-1/2" Sanitary Fitting
610-616, 680	7.00	177.8	1/4"
701-706, 15623, 15731-15736	6.63	168.4	1/4"
Differential Pressure			
540-543	8.47	215.1	1/8"
544-548	8.53	216.7	1/8"

Pressure Connections

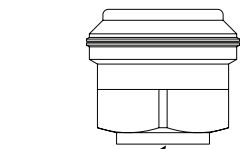

1/2 NPT
**Models 171-174,
 471-474**

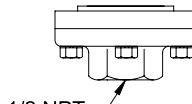

1/2 NPT
**Models 183-186,
 483-486**



1/2 NPT
**Models 188-194,
 488-494**

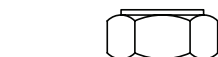

1/4 NPT
**Models 218-376,
 610-706, 15623, 15731-15736**

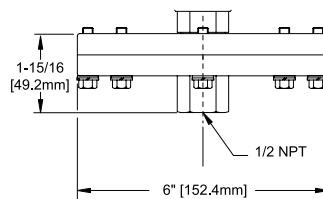

Models 520-525

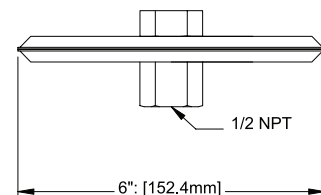

Models 530-535, 15737

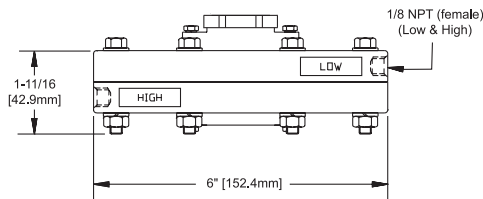

Model 540-543

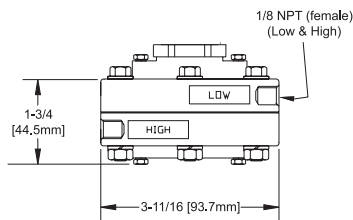

Models 544-548

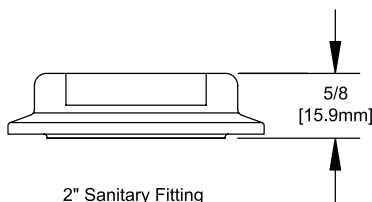

Models 560-564

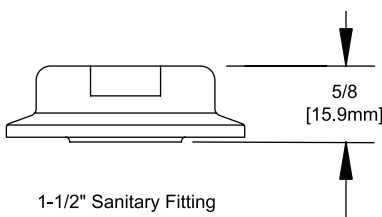

Models 565-567

RECOMMENDED PRACTICES AND WARNINGS

United Electric Controls Company recommends careful consideration of the following factors when specifying and installing UE pressure and temperature units. Before installing a unit, the Installation and Maintenance instructions provided with unit must be read and understood.

- To avoid damaging unit, proof pressure and maximum temperature limits stated in literature and on nameplates must never be exceeded, even by surges in the system. Operation of the unit up to maximum pressure or temperature is acceptable on a limited basis (e.g., start-up, testing) but continuous operation must be restricted to the designated adjustable range. Excessive cycling at maximum pressure or temperature limits could reduce sensor life.
- A back-up unit is necessary for applications where damage to a primary unit could endanger life, limb or property. A high or low limit switch is necessary for applications where a dangerous runaway condition could result.
- The adjustable range must be selected so that incorrect, inadvertent or malicious setting at any range point cannot result in an unsafe system condition.
- Install unit where shock, vibration and ambient temperature fluctuations will not damage unit or affect operation. When applicable, orient unit so that moisture does not enter the enclosure via the electrical connection. When appropriate, this entry point should be sealed to prevent moisture entry.
- Unit must not be altered or modified after shipment. Consult UE if modification is necessary.
- Monitor operation to observe warning signs of possible damage to unit, such as drift in set point or faulty display. Check unit immediately.
- Preventative maintenance and periodic testing is necessary for critical applications where damage could endanger property or personnel.
- Electrical ratings stated in literature and on nameplate must not be exceeded. Overload on a switch can cause damage, even on the first cycle. Wire unit according to local and national electrical codes, using wire size recommended in installation sheet.
- Do not mount unit in ambient temp. exceeding published limits.

LIMITED WARRANTY

Seller warrants that the product hereby purchased is, upon delivery, free from defects in material and workmanship and that any such product which is found to be defective in such workmanship or material will be repaired or replaced by Seller (Ex-works, Factory, Watertown, Massachusetts. INCOTERMS); provided, however, that this warranty applies only to equipment found to be so defective within a period of 36 months from the date of manufacture by the Seller. Seller shall not be obligated under this warranty for alleged defects which examination discloses are due to tampering, misuse, neglect, improper storage, and in any case where products are disassembled by anyone other than authorized Seller's representatives. EXCEPT FOR THE LIMITED WARRANTY OF REPAIR AND REPLACEMENT STATED ABOVE, SELLER DISCLAIMS ALL WARRANTIES WHATSOEVER WITH RESPECT TO THE PRODUCT, INCLUDING ALL IMPLIED WARRANTIES OF MERCHANTABILITY OR FITNESS FOR ANY PARTICULAR PURPOSE.

LIMITATION OF SELLER'S LIABILITY

SELLER'S LIABILITY TO BUYER FOR ANY LOSS OR CLAIM, INCLUDING LIABILITY INCURRED IN CONNECTION WITH (I) BREACH OF ANY WARRANTY WHATSOEVER, EXPRESSED OR IMPLIED, (II) A BREACH OF CONTRACT, (III) A NEGLIGENT ACT OR ACTS (OR NEGLIGENT FAILURE TO ACT) COMMITTED BY SELLER, OR (IV) AN ACT FOR WHICH STRICT LIABILITY WILL BE INPUTTED TO SELLER, IS LIMITED TO THE "LIMITED WARRANTY" OF REPAIR AND/OR REPLACEMENT AS SO STATED IN OUR WARRANTY OF PRODUCT. IN NO EVENT SHALL THE SELLER BE LIABLE FOR ANY SPECIAL, INDIRECT, CONSEQUENTIAL OR OTHER DAMAGES OF A LIKE GENERAL NATURE, INCLUDING, WITHOUT LIMITATION, LOSS OF PROFITS OR PRODUCTION, OR LOSS OR EXPENSES OF ANY NATURE INCURRED BY THE BUYER OR ANY THIRD PARTY.

UE specifications subject to change without notice.



UNITED ELECTRIC
CONTROLS

180 Dexter Ave. P.O. Box 9143, Watertown, MA 02472-9143 USA
617 926-1000 Fax 617 926-2568
www.ueonline.com